P3 | JOIST

USER GUIDE

CANADA 

 **INTERFOR[®]**

P3 Joist	02
<hr/>	
P3 Joist Labeling Example	02
Storage and Handling.....	03
Safety Precautions.....	03
Selecting a P3 Joist	04
<hr/>	
Maximum Allowable Spans	05
Allowable Floor Uniform Load Capacities - PJI 40 & 60	06
Allowable Floor Uniform Load Capacities - PJI 65.....	07
Allowable Floor Uniform Load Capacities - PJI 80	08
Allowable Floor Uniform Load Capacities - PJI 80 w/ Web Stiffeners.....	09
Allowable Floor Uniform Load Capacities - PJI 90	10
Allowable Floor Uniform Load Capacities - PJI 90 w/ Web Stiffeners.....	11
Floor Framing and Construction Details	12
<hr/>	
Installation Details and Web Stiffener Requirements	16
Cantilever Detail for Balconies.....	17
Cantilever Detail for Vertical Building Offset.....	18
Cantilever Reinforcement Methods.....	19
Typical Floor Framing Installation Notes	20
<hr/>	
Web Hole Rules and Specifications	20
<hr/>	
P3 Joist Typical Holes	21
<hr/>	
Typical P3 Joist Roof Framing and Construction Details	22
<hr/>	
Allowable Roof Spans - Simple Span	28
Allowable Roof Load Capacities - PJI 40.....	31
Allowable Roof Load Capacities - PJI 60.....	32
Allowable Roof Load Capacities - PJI 65	33
Allowable Roof Load Capacities - PJI 80.....	34
Allowable Roof Load Capacities - PJI 80 w/ Web Stiffeners	35
Allowable Roof Load Capacities - PJI 90.....	36
Allowable Roof Load Capacities - PJI 90 w/ Web Stiffeners	37
P3 Joist Design Properties	38
<hr/>	
Reaction Capacities for P3 Joist	38
<hr/>	
P3 Joist Framing Connectors — Single P3 Joist	39
<hr/>	
P3 Joist Framing Connectors — Double P3 Joist	40
<hr/>	
P3 Products Warranty	41
<hr/>	



INTERFOR[®]

THE PERFECT PRODUCT FOR EVERY PROJECT

Our P3 Joist conform to the APA's performance standards. We rigorously verify and test our products to ensure that they perform predictably and safely. Simple to specify. Easy to install. Less confusion.

P3 JOIST

Interfor has made it easy to make the right choice for residential and non-residential floor and roof joist products. P3 Joist are produced in accordance with Interfor's reports, ASTM D5055 and ASTM D7247. All code reports can be downloaded from our website www.interfor.com.

P3 Joist provide a high performance alternative to dimension lumber joists for floor and roof applications. This guide will help you efficiently use P3 Joist by leading you through the simple steps of product selection, specification, and installation.

The APA trademark signifies that the I-Joist manufacturer is committed to the strict quality standards of Engineered Wood Systems (EWS) – a related corporation of APA – and that P3 Joist are manufactured in conformance with ASTM D5055. APA's rigorous program of quality verification and testing is designed to assure predictable product performance.

This guide explains floor and roof systems. Review by a design professional is required for applications beyond the scope of this document.

Simple to specify. Easy to install. Less confusion. P3 Joist's the right choice for residential and non-residential floor and roof construction.

P3 Joist Labeling Example

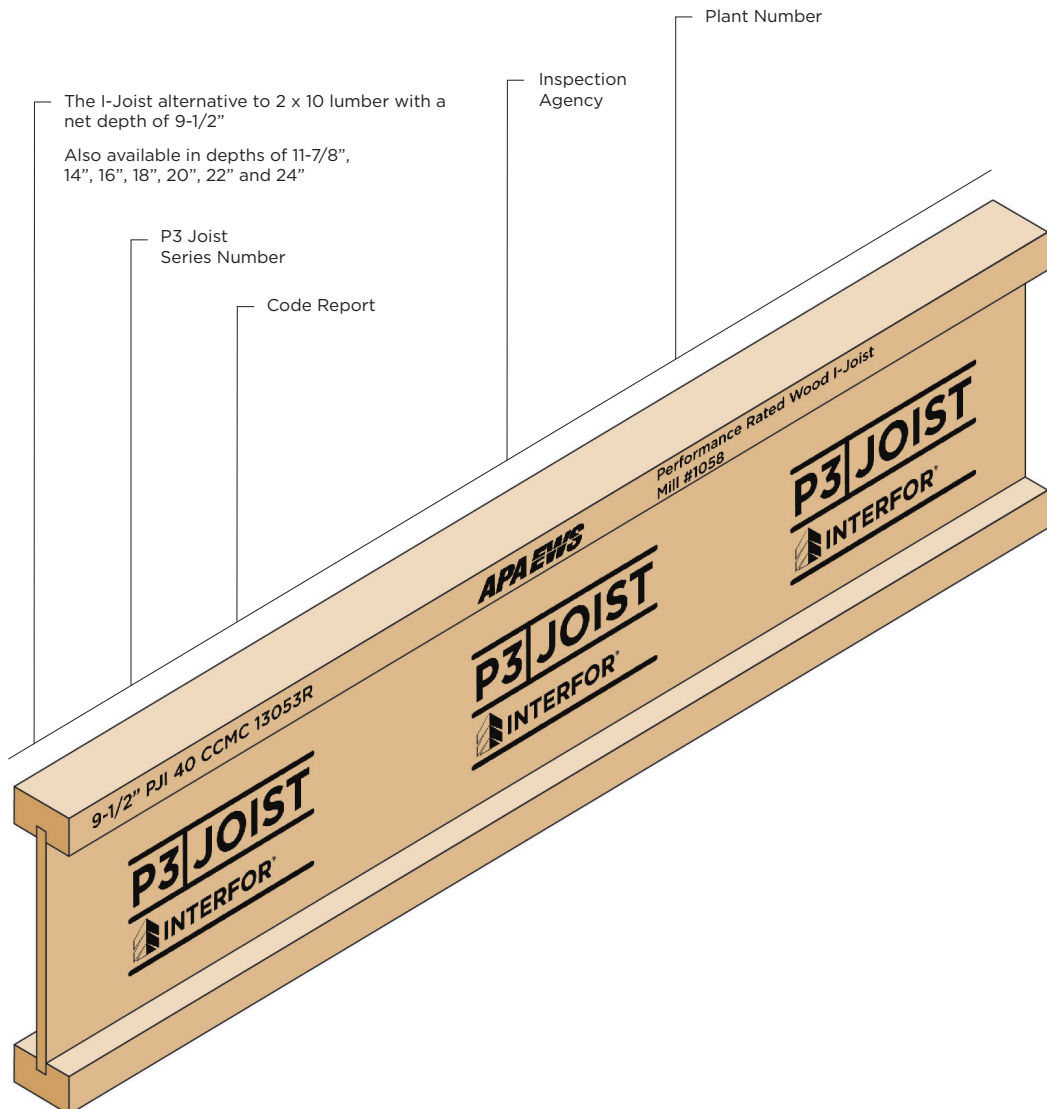

P3 JOIST (continued)

Storage and Handling Guidelines

1. Store, stack, and handle P3 Joists in a vertical and level position only.
2. Do not store P3 Joist in direct contact with the ground; do not store P3 Joists flatwise.
3. Protect P3 Joist from weather, and use stickers to separate bundles.
4. To protect P3 Joist further from dirt and weather, do not open bundles until time of installation.
5. When lifting P3 Joist with a crane on the job site, take a few simple precautions to prevent damage to the P3 Joist and to prevent injury to your work crew.
 - Lift P3 Joists in bundles as shipped by the supplier.
 - Orient the bundles so that the webs of the P3 Joist are vertical.
 - Lift the bundles at the 5th points, using a spreader bar if necessary.
6. Do not twist or apply loads to the P3 Joist when horizontal.
7. Never use or try to repair a damaged P3 Joist.

Safety Precautions

WARNING P3 Joists are not stable until completely installed and will not carry any load until fully braced and sheathed.

Avoid Accidents by Following These Important Guidelines.

1. Brace and nail each P3 Joist as it is installed, using hangers, blocking panels, rim board, and/or cross-bridging at joist ends. When P3 Joists are applied continuously over interior supports and a load-bearing wall is planned at the location, blocking will be required at the interior supports.
2. When the building is completed, the floor sheathing will provide lateral support for the top flanges of the P3 Joists. Until this sheathing is applied, temporary bracing, often called struts, or temporary sheathing must be applied to prevent P3 Joist rollover or buckling.
 - Temporary bracing or struts **must be** 1 x 4" minimum, at least 8' long, spaced no more than 8' on center, and secured with a minimum of two 8d nails fastened to the top surface of each P3 Joist. Nail bracing to a lateral restraint at the end of each bay. Lap ends of adjoining bracing over at least two P3 Joists.
 - Or, sheathing (temporary or permanent) can be nailed to the top flange of the first 4' of the P3 Joists at the end of the bay.
3. For cantilevered P3 Joists, brace top and bottom flanges, and brace ends with closure panels, rim board, or cross-bridging.
4. Install and nail permanent sheathing to each P3 Joist before placing loads on the floor system. Then, stack building materials over beams or walls only.
5. For temporary construction loads such as dry wall stacking, see APA Publication J735A (Temporary Construction Loads Over I-Joist Roofs).

Failure to follow applicable building codes and span ratings, failure to use allowable hole sizes and locations, or failure to use web stiffeners when required can result in serious accidents. Follow these installation guidelines carefully.

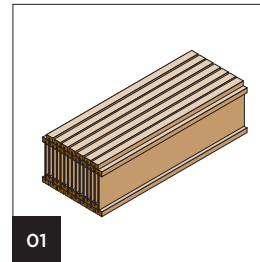

01

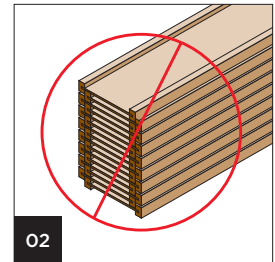

02

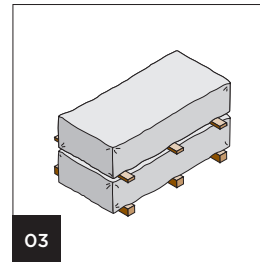

03

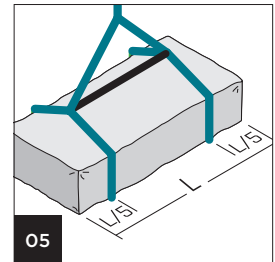

05

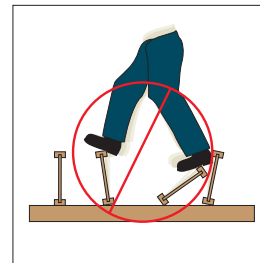

Do not allow workers to walk on P3 Joists until joists are fully installed and braced, or serious injuries can result.

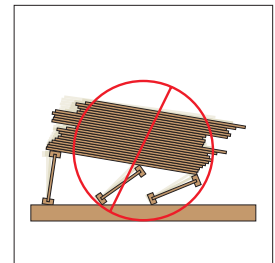

Never stack building materials over unsheathed P3 Joists. Stack only over beams or walls.

Selecting a P3 JOIST

Product Description

The P3 Joist is an "I"-shaped engineered wood structural member designed for use in residential and non-residential floor and roof construction. P3 Joists are prefabricated using SPF MSR lumber flanges and OSB web, which are bonded together with exterior-type adhesives. It is recommended that P3 Joists be designed in accordance with the CCMC vibration procedure for residential floor applications, a criteria which provides superior floor performance. P3 Joist are limited to a L/480 maximum live load deflection for residential and non-residential floor applications. P3 Joists are identified by their depth followed by a designation such as PJI 40 which relates to the joist strength and stiffness. P3 Joist are manufactured to strict tolerances with the following characteristics.

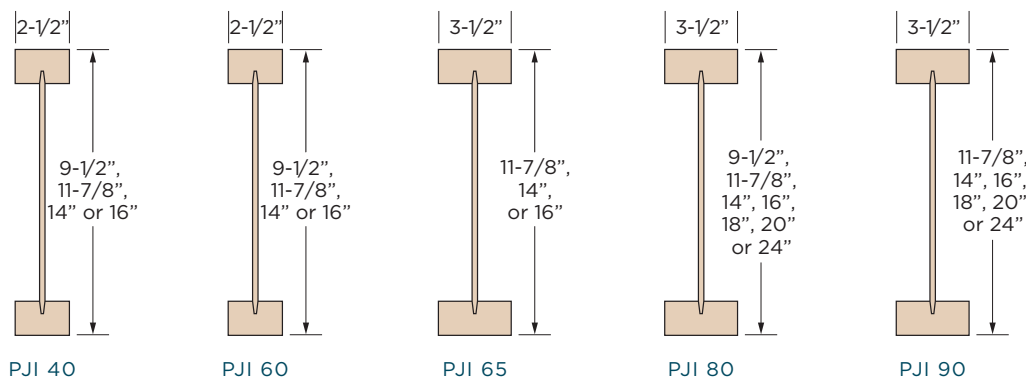

- **Flanges** are MSR 2x3's and 2x4's
- **Webs** are OSB, and all are classified as Exposure 1 or Exterior and are 3/8" in thickness or greater.
- All P3 Joists are assembled using exterior-type adhesives that meet ASTM D2559 and ASTM D7247.
- P3 Joist are available in seven depths: 9-1/2", 11-7/8", 14", 16", 18", 20" and 24".
- P3 Joist of the same depth are manufactured with various flange widths; flange width is an important design consideration when specifying hangers.
- P3 Joist are manufactured up to 64' in length. These lengths are cut to used lengths such as 16' to 36' in 2' increments for jobsite delivery. Check local supplier for availability.
- P3 Joists are listed and approved in Canada under CCMC 13053R and Ontario Minister's Ruling #07-16-174.

Allowable Floor Spans

Maximum Allowable Spans

The specific PJI designation needed for your application is easily determined by selecting the span needed and then by choosing the PJI that meets your span, spacing, and uniform loading criteria.

Tables 1 and 1a are for simple or multiple span applications respectively. The use of these tables will provide maximum spans for the indicated spacing and span conditions.

To illustrate the selection of a P3 Joist product, assume a design simple span of 15'-10" for 40/15 loading. For architectural reasons limit the P3 Joist depth to 11-7/8" and P3 Joist spacing to 19.2" on center with 5/8" plywood subfloor. From the 11-7/8" entry in Table 1, look down the 19.2" o.c. spacing column. Select PJI 40 11-7/8" P3 Joist.

While any of the P3 Joists shown in Tables 1 and 1a may be available in a specific market area, availability of any P3 Joist product should be verified prior to final product selection.

The allowable spans in the tables in this user guide indicate the allowable simple and multiple spans for various joist spacings under typical residential uniform floor loads (40 psf live load and 15 psf dead load) for glued-nailed systems.

Floor sheathing **must be field glued** to the P3 Joist flanges using approved construction adhesives to achieve the P3 Joist allowable spans.

Use of these span tables is limited to uniform load conditions and P3 Joist floor spans shall not exceed these allowable spans. P3 Joist can be used for other applications such as roofs and ceilings to support line loads or concentrated loads, etc., when properly engineered.

NOTES

- Design in accordance with CSA O86-19 and CCMC vibration concluding report dated September 4, 1997.
- Web stiffeners are not required for P3 Joists up to 16" deep. **Joists 18" and deeper require stiffeners at each support.**
- Use in dry service conditions only.
- Provide lateral support at points of bearing to prevent twisting of joists.
- Uniform load deflection criteria is L/480 on live load and L/240 on total load calculated.
- Elastomeric adhesives for gluing of the subfloor shall conform to CGSB Standard CAN-CGSB-71.26-M88
- Minimum end bearing length to be 1-3/4" and 3-1/2" for intermediate bearing supports.
- Vibration spans are based on 19/32" OSB or 5/8" Canadian Softwood Plywood for joist spacing of 12" to 19.2" and on 23/32" OSB or 3/4" Canadian Softwood Plywood for joists spaced at 24" o/c. No ceiling, concrete topping, or bridging elements.**
- Spans listed are clear distances between supports.

TABLE 1
Allowable Spans for P3 Floor Joist
Single span only - Glued & Nailed subfloor

Load		Series	Depth (in)	Maximum Floor Span (ft - in)			
Live (psf)	Dead (psf)			Glued & Nailed subfloor			
				On center spacing (in)			
			12	16	19.2	24	
40	15	PJI 40	9 1/2	15-6"	14-8"	14-2"	14-2"
			11 7/8	17-5"	16-5"	15-11"	16-0"
			14	19-3"	17-10"	17-3"	17-5"
			16	20-11"	19-5"	18-7"	18-10"
		PJI 60	9 1/2	16-0"	15-1"	14-7"	14-9"
			11 7/8	18-0"	16-11"	16-5"	16-6"
			14	20-0"	18-7"	17-10"	17-11"
			16	21-10"	20-3"	19-5"	19-7"
		PJI 65	11 7/8	18-7"	17-4"	16-9"	16-11"
			14	20-8"	19-1"	18-3"	18-5"
			16	22-6"	20-9"	19-11"	20-0"
			PJI 80	9 1/2	16-11"	15-11"	15-5"
	11 7/8	19-4"		17-11"	17-3"	17-5"	
	14	21-6"		19-11"	19-0"	19-2"	
	16	23-5"		21-8"	20-8"	20-10"	
	18	25-3"		23-4"	22-3"	22-5"	
	20	27-0"		24-11"	23-9"	23-11"	
	24	30-3"		27-11"	26-8"	26-9"	
	PJI 90	11 7/8		19-9"	18-3"	17-7"	17-8"
		14	22-0"	20-3"	19-5"	19-6"	
		16	23-11"	22-1"	21-1"	21-3"	
		18	25-9"	23-9"	22-8"	22-10"	
			20	27-6"	25-5"	24-3"	24-4"
			24	30-10"	28-6"	27-2"	27-3"

TABLE 1 A
Allowable Spans for P3 Floor Joist
Multiple spans only - Glued & Nailed subfloor

Load		Series	Depth (in)	Maximum Floor Span (ft - in)			
Live (psf)	Dead (psf)			Glued & Nailed subfloor			
				On center spacing (in)			
			12	16	19.2	24	
40	15	PJI 40	9 1/2	16-1"	15-2"	14-8"	14-10"
			11 7/8	18-2"	17-0"	16-6"	16-7"
			14	20-2"	18-8"	17-11"	18-1"
			16	22-0"	20-5"	19-6"	19-8"
		PJI 60	9 1/2	16-7"	15-7"	15-1"	15-3"
			11 7/8	18-11"	17-7"	17-0"	17-1"
			14	21-0"	19-6"	18-8"	18-10"
			16	22-11"	21-3"	20-4"	20-6"
		PJI 65	11 7/8	19-6"	18-0"	17-4"	17-6"
			14	21-8"	20-0"	19-2"	19-4"
			16	23-7"	21-10"	20-11"	21-0"
			PJI 80	9 1/2	17-7"	16-6"	15-11"
	11 7/8	20-4"		18-9"	18-0"	18-1"	
	14	22-7"		20-11"	20-0"	20-1"	
	16	24-8"		22-9"	21-9"	21-11"	
	18	26-6"		24-6"	23-5"	23-6"	
	20	28-5"		26-2"	25-0"	25-2"	
	24	31-11"		29-5"	28-0"	28-2"	
	PJI 90	11 7/8		20-9"	19-2"	18-4"	18-6"
		14	23-1"	21-4"	20-4"	20-6"	
		16	25-2"	23-2"	22-2"	22-3"	
		18	27-1"	25-0"	23-10"	24-0"	
			20	29-0"	26-9"	25-6"	25-8"
			24	32-9"	30-0"	28-7"	28-8"

*For other type floor assemblies, please visit www.interfor.com

Allowable Floor Uniform Load Capacities

TABLE 2
P3 Floor Joist — PJI 40
 Allowable Uniform Loads (PLF)

Clear Span (ft)	9-1/2"				11-7/8"				14"				16"			
	Unfactored Loads Based on Deflection			Factored Total Load	Unfactored Loads Based on Deflection			Factored Total Load	Unfactored Loads Based on Deflection			Factored Total Load	Unfactored Loads Based on Deflection			Factored Total Load
	Live		Total L/240		Live		Total L/240		Live		Total L/240		Live		Total L/240	
	L/480	L/360		L/480	L/360	L/480		L/360	L/480	L/360		L/480	L/360			
8	288	384	-	419	-	-	-	419	-	-	-	419	-	-	-	419
9	215	287	-	374	343	-	-	374	-	-	-	374	-	-	-	374
10	164	219	328	338	265	-	-	338	-	-	-	338	-	-	-	338
11	128	170	256	285	208	277	-	308	291	-	-	308	-	-	-	308
12	101	135	202	240	166	221	-	283	233	-	-	283	-	-	-	283
13	81	108	163	205	134	179	-	261	190	253	-	261	251	-	-	261
14	66	88	133	178	110	146	220	230	156	208	-	243	207	-	-	243
15	55	73	110	155	91	121	182	201	130	173	-	227	173	-	-	227
16	45	61	91	137	76	102	153	177	109	145	-	213	145	194	-	213
17	38	51	77	121	64	86	129	157	92	123	185	190	123	165	-	201
18	32	43	65	108	55	73	110	140	79	105	158	169	105	141	-	190
19	28	37	56	97	47	63	94	126	68	90	136	152	91	121	-	176
20	24	32	48	88	41	54	82	114	59	78	118	137	79	105	158	159
21	21	28	42	80	35	47	71	104	51	68	102	125	69	92	138	145
22	18	24	37	73	31	41	62	94	45	60	90	114	60	81	121	132
23	16	21	32	67	27	36	55	86	39	53	79	104	53	71	107	121
24	14	19	28	61	24	32	48	79	35	47	70	96	47	63	95	111
25	12	17	25	56	21	28	43	73	31	41	62	88	42	56	84	102
26	11	15	22	52	19	25	38	68	28	37	56	82	37	50	75	95
27	10	13	20	48	17	23	34	63	25	33	50	76	33	45	67	88
28	9	12	18	45	15	20	31	58	22	30	45	70	30	40	61	82
29	8	11	16	42	14	18	28	54	20	27	40	66	27	36	55	76
30	7	10	15	39	12	17	25	51	18	24	37	61	25	33	50	71
31	6	9	13	37	11	15	23	48	16	22	33	58	22	30	45	67

See notes under Table 6A

TABLE 3
P3 Floor Joist — PJI 60
 Allowable Uniform Loads (PLF)

Clear Span (ft)	9-1/2"				11-7/8"				14"				16"			
	Unfactored Loads Based on Deflection			Factored Total Load	Unfactored Loads Based on Deflection			Factored Total Load	Unfactored Loads Based on Deflection			Factored Total Load	Unfactored Loads Based on Deflection			Factored Total Load
	Live		Total L/240		Live		Total L/240		Live		Total L/240		Live		Total L/240	
	L/480	L/360		L/480	L/360	L/480		L/360	L/480	L/360		L/480	L/360			
8	330	-	-	419	-	-	-	419	-	-	-	419	-	-	-	419
9	248	331	-	374	-	-	-	374	-	-	-	374	-	-	-	374
10	190	254	-	338	305	-	-	338	-	-	-	338	-	-	-	338
11	149	198	298	308	241	-	-	308	-	-	-	308	-	-	-	308
12	118	158	237	283	193	257	-	283	272	-	-	283	-	-	-	283
13	95	127	191	261	157	209	-	261	222	-	-	261	-	-	-	261
14	78	104	156	243	129	172	-	243	183	-	-	243	243	-	-	243
15	64	86	129	215	107	143	214	227	153	204	-	227	203	-	-	227
16	54	72	108	189	90	120	180	213	129	172	-	213	172	-	-	213
17	45	61	91	168	76	101	152	201	109	146	-	201	146	195	-	201
18	39	52	78	150	65	86	130	190	94	125	188	190	125	167	-	190
19	33	44	67	135	56	74	112	175	81	108	162	180	108	144	-	180
20	28	38	57	122	48	64	97	158	70	93	140	171	94	126	-	171
21	25	33	50	110	42	56	84	143	61	81	122	163	82	110	-	163
22	22	29	44	101	37	49	74	131	53	71	107	156	72	96	145	156
23	19	25	38	92	32	43	65	120	47	63	95	144	64	85	128	149
24	17	22	34	85	29	38	58	110	42	56	84	132	56	75	113	143
25	15	20	30	78	25	34	51	101	37	50	75	122	50	67	101	137
26	13	18	27	72	23	30	46	94	33	44	67	113	45	60	90	131
27	12	16	24	67	20	27	41	87	30	40	60	105	40	54	81	122
28	10	14	21	62	18	24	37	81	27	36	54	98	36	49	73	113
29	9	13	19	58	16	22	33	75	24	32	49	91	33	44	66	106
30	8	11	17	54	15	20	30	71	22	29	44	85	30	40	60	99
31	8	10	16	51	13	18	27	66	20	27	40	80	27	36	55	92

See notes under Table 6A

Allowable Floor Uniform Load Capacities (continued)

TABLE 4
P3 Floor Joist — PJI 65
 Allowable Uniform Loads (PLF)

Clear Span (ft)	11-7/8"				14"				16"			
	Unfactored Loads Based on Deflection			Factored Total Load	Unfactored Loads Based on Deflection			Factored Total Load	Unfactored Loads Based on Deflection			Factored Total Load
	Live		Total L/240		Live		Total L/240		Live		Total L/240	
	L/480	L/360		L/480	L/360	L/480		L/360				
8	-	-	-	427	-	-	-	459	-	-	-	460
9	-	-	-	381	-	-	-	410	-	-	-	410
10	337	-	-	344	-	-	-	370	-	-	-	370
11	268	-	-	314	-	-	-	337	-	-	-	337
12	215	287	-	288	300	-	-	310	-	-	-	310
13	175	234	-	266	246	-	-	286	-	-	-	286
14	145	193	-	248	204	-	-	266	-	-	-	266
15	120	161	-	232	170	227	-	248	224	-	-	248
16	101	135	203	217	144	192	-	233	190	-	-	233
17	86	115	172	205	122	163	-	220	162	216	-	220
18	73	98	147	193	105	140	-	207	139	186	-	207
19	63	84	127	177	90	121	181	197	120	160	-	197
20	55	73	110	160	78	105	157	187	105	140	-	187
21	48	64	96	145	69	92	138	175	92	122	-	178
22	42	56	84	133	60	80	121	160	80	107	161	170
23	37	49	74	121	53	71	107	146	71	95	143	163
24	33	44	66	112	47	63	95	134	63	84	127	156
25	29	39	58	103	42	56	84	124	56	75	113	144
26	26	35	52	95	37	50	75	115	50	67	101	133
27	23	31	47	88	34	45	68	106	45	60	91	124
28	21	28	42	82	30	40	61	99	41	54	82	115
29	19	25	38	77	27	37	55	92	37	49	74	107
30	17	23	34	72	25	33	50	86	33	45	67	100
31	15	21	31	67	22	30	45	81	30	41	61	94

See notes under Table 6A

Allowable Floor Uniform Load Capacities (continued)

TABLE 5
P3 Floor Joist — PJI 80
 Allowable Uniform Loads (PLF)

Clear Span (ft)	9-1/2"				11-7/8"				14"				16"			
	Unfactored Loads Based on Deflection			Factored Total Load	Unfactored Loads Based on Deflection			Factored Total Load	Unfactored Loads Based on Deflection			Factored Total Load	Unfactored Loads Based on Deflection			Factored Total Load
	Live		Total L/240		Live		Total L/240		Live		Total L/240		Live		Total L/240	
	L/480	L/360		L/480	L/360	L/480		L/360	L/480	L/360		L/480	L/360			
8	415	-	-	420	-	-	-	427	-	-	-	459	-	-	-	497
9	317	-	-	375	-	-	-	381	-	-	-	410	-	-	-	443
10	246	328	-	338	-	-	-	344	-	-	-	370	-	-	-	400
11	194	259	-	308	308	-	-	314	-	-	-	337	-	-	-	365
12	156	208	-	283	249	-	-	288	-	-	-	310	-	-	-	335
13	126	169	253	262	204	-	-	266	284	-	-	286	-	-	-	310
14	104	139	208	243	169	225	-	248	237	-	-	266	-	-	-	288
15	86	115	173	227	141	188	-	232	199	-	-	249	261	-	-	269
16	72	97	145	213	119	159	-	217	168	224	-	234	222	-	-	253
17	61	82	123	201	101	135	203	205	144	192	-	220	190	-	-	238
18	52	70	105	190	87	116	174	193	123	165	-	208	163	218	-	225
19	45	60	90	180	75	100	150	183	107	142	-	197	142	189	-	213
20	39	52	78	171	65	87	130	174	93	124	186	187	124	165	-	203
21	34	45	68	157	57	76	114	166	81	108	163	179	108	145	-	193
22	30	40	60	143	50	66	100	159	71	95	143	171	96	128	-	184
23	26	35	53	131	44	59	88	152	63	84	127	163	85	113	170	177
24	23	31	47	121	39	52	78	146	56	75	113	156	75	100	151	169
25	20	27	41	111	34	46	69	140	50	67	100	150	67	90	135	163
26	18	24	37	103	31	41	62	134	45	60	90	145	60	80	121	156
27	16	22	33	96	28	37	56	124	40	54	81	139	54	72	109	151
28	15	20	30	89	25	33	50	115	36	48	73	134	49	65	98	145
29	13	18	27	83	22	30	45	108	33	44	66	130	44	59	89	140
30	12	16	24	77	20	27	41	101	30	40	60	121	40	54	81	136
31	11	14	22	73	18	25	37	94	27	36	54	114	36	49	73	131

See notes under Table 6A

Allowable Floor Uniform Load Capacities (continued)

TABLE 5A
P3 Floor Joist — PJI 80 with Web Stiffeners
 Allowable Uniform Loads (PLF)

Clear Span (ft)	18"				20"				24"			
	Unfactored Loads Based on Deflection			Factored Total Load	Unfactored Loads Based on Deflection			Factored Total Load	Unfactored Loads Based on Deflection			Factored Total Load
	Live		Total L/240		Live		Total L/240		Live		Total L/240	
	L/480	L/360		L/480	L/360	L/480		L/360				
8	-	-	-	601	-	-	-	601	-	-	-	601
9	-	-	-	536	-	-	-	536	-	-	-	536
10	-	-	-	484	-	-	-	484	-	-	-	484
11	-	-	-	441	-	-	-	441	-	-	-	441
12	-	-	-	405	-	-	-	405	-	-	-	405
13	-	-	-	375	-	-	-	375	-	-	-	375
14	-	-	-	349	-	-	-	349	-	-	-	349
15	-	-	-	326	-	-	-	326	-	-	-	326
16	278	-	-	306	-	-	-	306	-	-	-	306
17	239	-	-	288	-	-	-	288	-	-	-	288
18	206	-	-	272	255	-	-	272	-	-	-	272
19	179	239	-	258	222	-	-	258	-	-	-	258
20	157	209	-	245	194	-	-	245	-	-	-	245
21	138	184	-	234	171	228	-	234	-	-	-	234
22	121	162	-	223	151	202	-	223	218	-	-	223
23	108	144	-	214	134	179	-	214	195	-	-	214
24	96	128	192	205	120	160	-	205	174	-	-	205
25	86	114	172	197	107	143	-	197	156	-	-	197
26	77	103	154	189	96	128	-	189	140	187	-	189
27	69	92	139	182	87	116	174	182	127	169	-	182
28	62	83	125	176	78	105	157	176	115	153	-	176
29	57	76	114	170	71	95	142	170	104	139	-	170
30	51	69	103	159	65	86	130	164	95	127	-	164
31	47	63	94	149	59	79	118	159	87	116	-	159
32	43	57	86	140	54	72	108	154	79	106	-	154
33	39	52	79	132	49	66	99	146	73	97	146	149
34	36	48	72	124	45	61	91	137	67	89	134	145
35	33	44	67	117	42	56	84	130	62	82	124	141
36	30	41	61	111	38	51	77	123	57	76	114	137
37	28	38	57	105	35	47	71	116	53	70	106	133
38	26	35	53	99	33	44	66	110	49	65	98	130
39	24	32	49	94	30	41	61	104	45	61	91	124
40	22	30	45	90	28	38	57	99	42	56	85	118
41	21	28	42	85	26	35	53	95	39	52	79	113
42	19	26	39	81	25	33	50	90	37	49	74	107
43	18	24	37	78	23	31	46	86	34	46	69	102
44	17	23	34	74	21	29	43	82	32	43	64	98

See notes under Table 6A

Allowable Floor Uniform Load Capacities (continued)

TABLE 6
P3 Floor Joist — PJI 90
 Allowable Uniform Loads (PLF)

Clear Span (ft)	11-7/8"				14"				16"			
	Unfactored Loads Based on Deflection			Factored Total Load	Unfactored Loads Based on Deflection			Factored Total Load	Unfactored Loads Based on Deflection			Factored Total Load
	Live		Total L/240		Live		Total L/240		Live		Total L/240	
L/480	L/360		L/480	L/360		L/480	L/360		L/480	L/360		
8	-	-	-	427	-	-	-	459	-	-	-	497
9	-	-	-	381	-	-	-	410	-	-	-	443
10	-	-	-	344	-	-	-	370	-	-	-	400
11	-	-	-	314	-	-	-	337	-	-	-	365
12	267	-	-	288	-	-	-	310	-	-	-	335
13	219	-	-	266	-	-	-	286	-	-	-	310
14	182	243	-	248	253	-	-	266	-	-	-	288
15	152	203	-	232	213	-	-	249	-	-	-	269
16	129	172	-	217	181	-	-	234	237	-	-	253
17	110	146	-	205	155	206	-	220	203	-	-	238
18	94	125	188	193	133	178	-	208	175	-	-	225
19	81	108	163	183	115	154	-	197	152	203	-	213
20	70	94	141	174	100	134	-	187	133	177	-	203
21	62	82	124	166	88	117	176	179	117	156	-	193
22	54	72	109	159	77	103	155	171	103	137	-	184
23	48	64	96	152	68	91	137	163	91	122	-	177
24	42	57	85	146	61	81	122	156	81	108	163	169
25	38	50	76	140	54	72	109	150	72	97	145	163
26	34	45	68	134	49	65	98	145	65	87	130	156
27	30	40	61	130	44	58	88	139	58	78	117	151
28	27	36	55	125	39	53	79	134	53	70	106	145
29	25	33	50	121	36	48	72	130	48	64	96	140
30	22	30	45	117	32	43	65	125	43	58	87	136
31	20	27	41	113	29	39	59	121	39	53	79	131

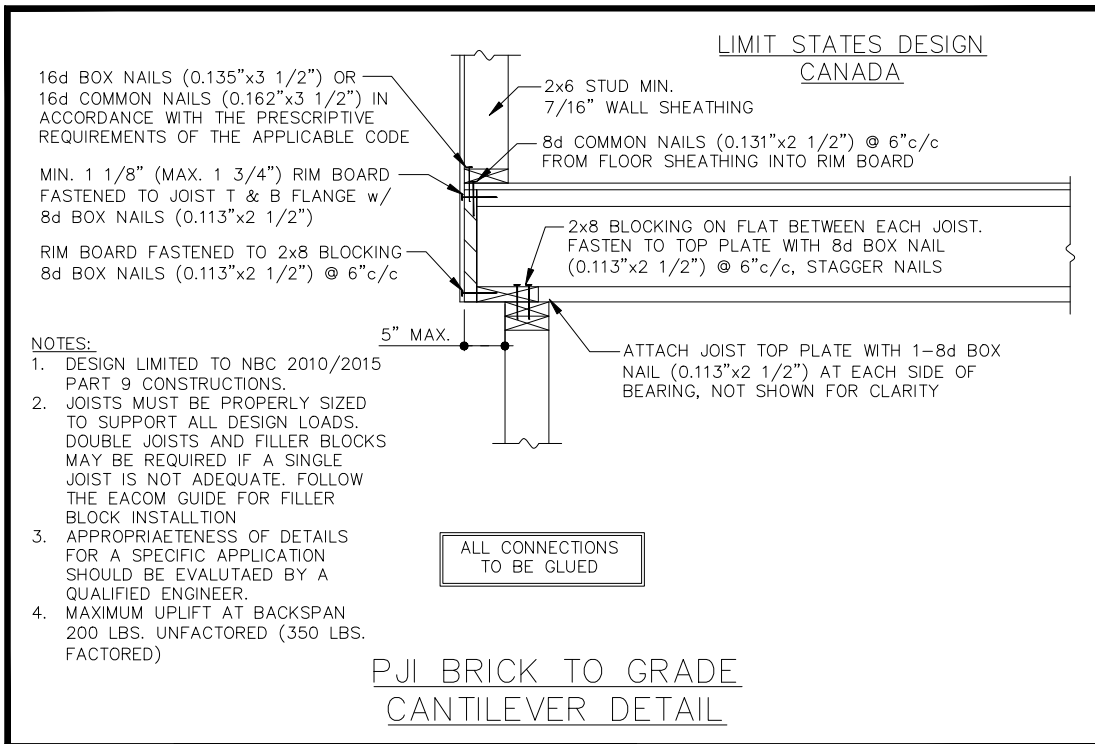

Figure 1: PJI Brick Cantilever Detail

Allowable Floor Uniform Load Capacities (continued)

TABLE 6A
P3 Floor Joist — PJI 90 With Web Stiffeners
 Allowable Uniform Loads (PLF)

Clear Span (ft)	18"				20"				24"			
	Unfactored Loads Based on Deflection			Factored Total Load	Unfactored Loads Based on Deflection			Factored Total Load	Unfactored Loads Based on Deflection			Factored Total Load
	Live		Total L/240		Live		Total L/240		Live		Total L/240	
	L/480	L/360		L/480	L/360	L/480		L/360				
8	-	-	-	601	-	-	-	601	-	-	-	601
9	-	-	-	536	-	-	-	536	-	-	-	536
10	-	-	-	484	-	-	-	484	-	-	-	484
11	-	-	-	441	-	-	-	441	-	-	-	441
12	-	-	-	405	-	-	-	405	-	-	-	405
13	-	-	-	375	-	-	-	375	-	-	-	375
14	-	-	-	349	-	-	-	349	-	-	-	349
15	-	-	-	326	-	-	-	326	-	-	-	326
16	298	-	-	306	-	-	-	306	-	-	-	306
17	256	-	-	288	-	-	-	288	-	-	-	288
18	222	-	-	272	-	-	-	272	-	-	-	272
19	193	257	-	258	238	-	-	258	-	-	-	258
20	169	225	-	245	209	-	-	245	-	-	-	245
21	149	198	-	234	184	-	-	234	-	-	-	234
22	131	175	-	223	163	217	-	223	-	-	-	223
23	116	155	-	214	145	193	-	214	209	-	-	214
24	104	139	-	205	129	172	-	205	187	-	-	205
25	93	124	186	197	116	154	-	197	168	-	-	197
26	83	111	167	189	104	139	-	189	151	-	-	189
27	75	100	151	182	94	125	-	182	137	-	-	182
28	68	91	136	176	85	113	170	176	124	165	-	176
29	61	82	123	170	77	103	154	170	113	150	-	170
30	56	75	112	164	70	94	141	164	103	137	-	164
31	51	68	102	159	64	85	128	159	94	125	-	159
32	47	62	94	154	58	78	117	154	86	115	-	154
33	43	57	86	149	54	72	108	149	79	105	-	149
34	39	52	79	145	49	66	99	145	73	97	-	145
35	36	48	72	141	45	61	91	141	67	89	134	141
36	33	44	67	135	42	56	84	137	62	83	124	137
37	31	41	62	128	39	52	78	133	57	76	115	133
38	28	38	57	122	36	48	72	130	53	71	106	130
39	26	35	53	115	33	44	67	126	49	66	99	126
40	24	33	49	110	31	41	62	122	46	61	92	123
41	23	30	46	104	29	38	58	116	43	57	86	120
42	21	28	43	100	27	36	54	110	40	53	80	117
43	20	26	40	95	25	33	50	105	37	50	75	115
44	18	25	37	91	23	31	47	100	35	47	70	112

NOTES for Tables 2, 3, 4, 5, 5A, 6 and 6A

1. Clear span is the distance between the face of the supports.
2. The load values are for standard term load duration and dry service conditions only. The dead load must not exceed the live load.
3. The load values represent the worst case of simple span or multiple span single member applications.
4. Design of continuous spans is based on the longest span. The shortest span must not be less than 50% of the longest span.
5. Provide continuous lateral support for top & bottom flanges. Provide lateral support at points of bearing to prevent twisting of joist.
6. The unfactored load columns are based on deflection only. The factored load column is based on strength only. Unfactored live load (either L/480 or L/360), unfactored total load and factored load must be checked. Where the unfactored load column is blank, the factored load column governs.
7. Provide minimum 1-3/4" bearing at end supports and 3-1/2" bearing at interior supports.
8. Web stiffeners are not required for the joists in tables 2, 3, 4, 5, and 6.
9. Web stiffeners are required for all joists at each bearing support in Table 5A and 6A.
10. The loads have been calculated in accordance with CSA O86 and NBCC.
11. Vibration is not included in the design criteria for this table.

Floor Framing and Construction Details

FIGURE 2
Typical P3 Floor Joist Framing and Construction Details

All nails shown in the details below are assumed to be common nails unless otherwise noted. Framing lumber is assumed to be Spruce-Pine-Fir. Individual components are not shown to scale for clarity.

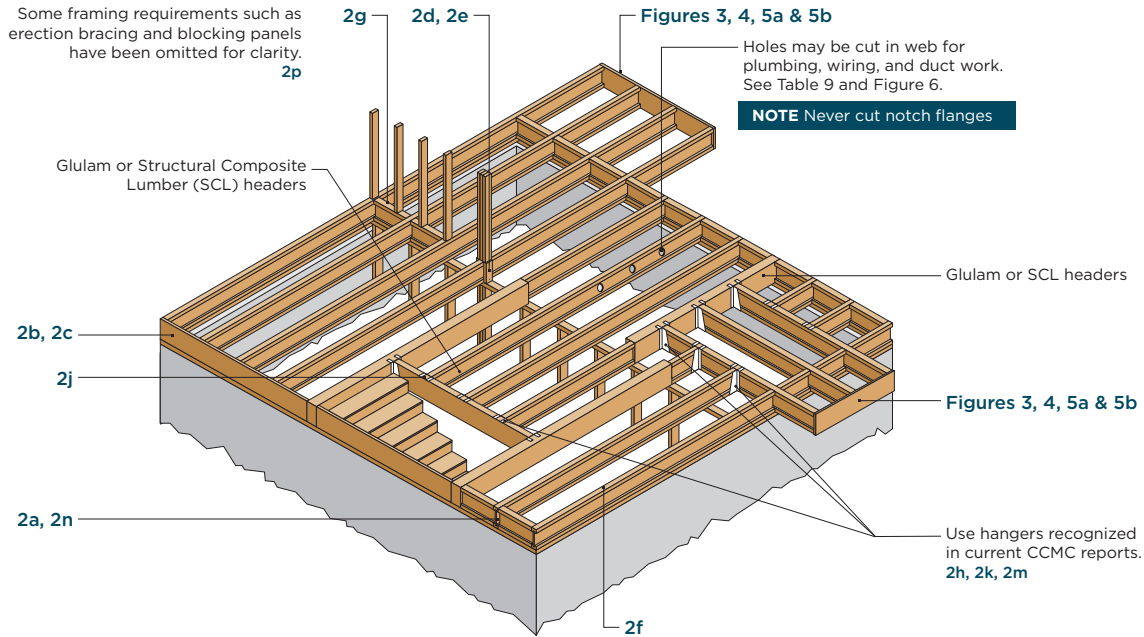

Blocking Panel or Rim Joist	Maximum Factored Uniform Vertical Load* (plf)
P3 PJI Joist (9-1/2" - 18")	2900

*The uniform vertical load capacity is limited to a joist depth of 18" or less and is based on the standard term load duration. It shall not be used in the design of a bending member such as joist, header, or rafter. For concentrated vertical load transfer capacity, see 2d.

2a **BLOCKING PANEL AT END SUPPORT DETAIL**

Blocking Panel or Rim Joist	Maximum Factored Uniform Vertical Load* (plf)
1-1/8" APA Rim Board Plus	7033
1-1/8" APA Rim Board	7033
1" APA Rim Board	4785

*The uniform vertical load capacity is limited to a rim board depth of 16" or less and is based on standard term load duration. It shall not be used in the design of a bending member such as joist, header, or rafter. For concentrated vertical load transfer capacity, see 2d.

To avoid splitting flange, start nails at least 1-1/2" from end of P3 Joist. Nails may be driven at an angle to avoid splitting of bearing plate.

2b **RIM BOARD DETAIL**

FIGURE 2 (CONTINUED)

Typical P3 Floor Joist Framing and Construction Details

All nails shown in the details below are assumed to be common nails unless otherwise noted. Framing lumber is assumed to be Spruce-Pine-Fir. Individual components are not shown to scale for clarity.

2c P3 JOIST AS RIM JOIST DETAIL

Pair of Squash Blocks	Maximum Factored Vertical Load per Pair of Squash Blocks (lb)	
	3-1/2" wide	5-1/2" wide
2x lumber	5800	9500
1-1/8" APA Rim Board, Rim Board Plus, or Rated Sturd-I-Floor 48 oc	4500	5800
1" APA Rim Board or Rated Sturd-I-Floor 32 oc	4000	5800

Provide lateral bracing per 2a, 2b, or 2c.

2d SQUASH BLOCK DETAIL

2e LOAD TRANSFER WITH PASS THRU BLOCKING DETAIL

2f PARALLEL END P3 JOIST DETAIL

APA Rim Board may be used in lieu of P3 Joist. Backer is not required when APA Rim Board is used.

FIGURE 2 (CONTINUED)

Typical P3 Floor Joist Framing and Construction Details

All nails shown in the details below are assumed to be common nails unless otherwise noted. Framing lumber is assumed to be Spruce-Pine-Fir. Individual components are not shown to scale for clarity.

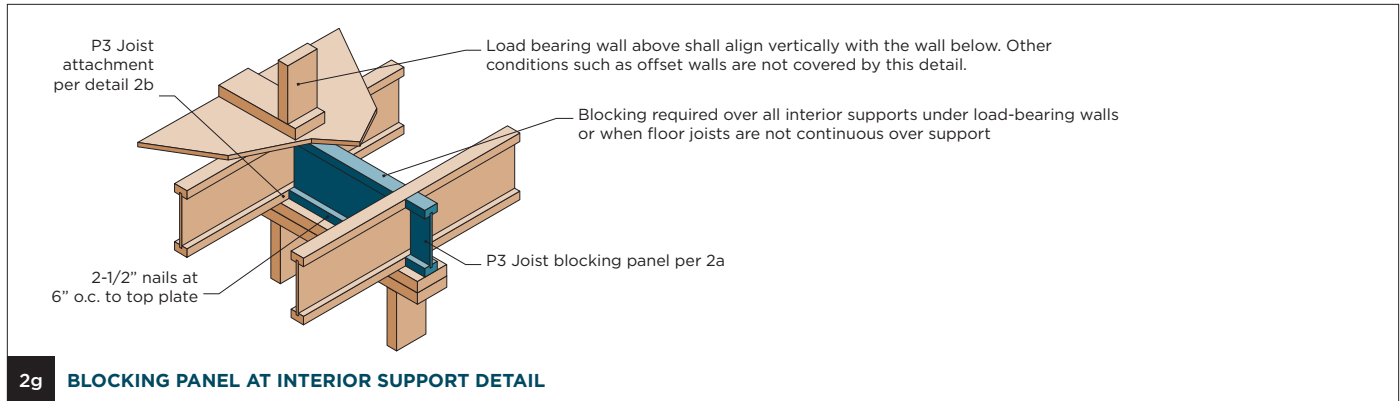

2g BLOCKING PANEL AT INTERIOR SUPPORT DETAIL

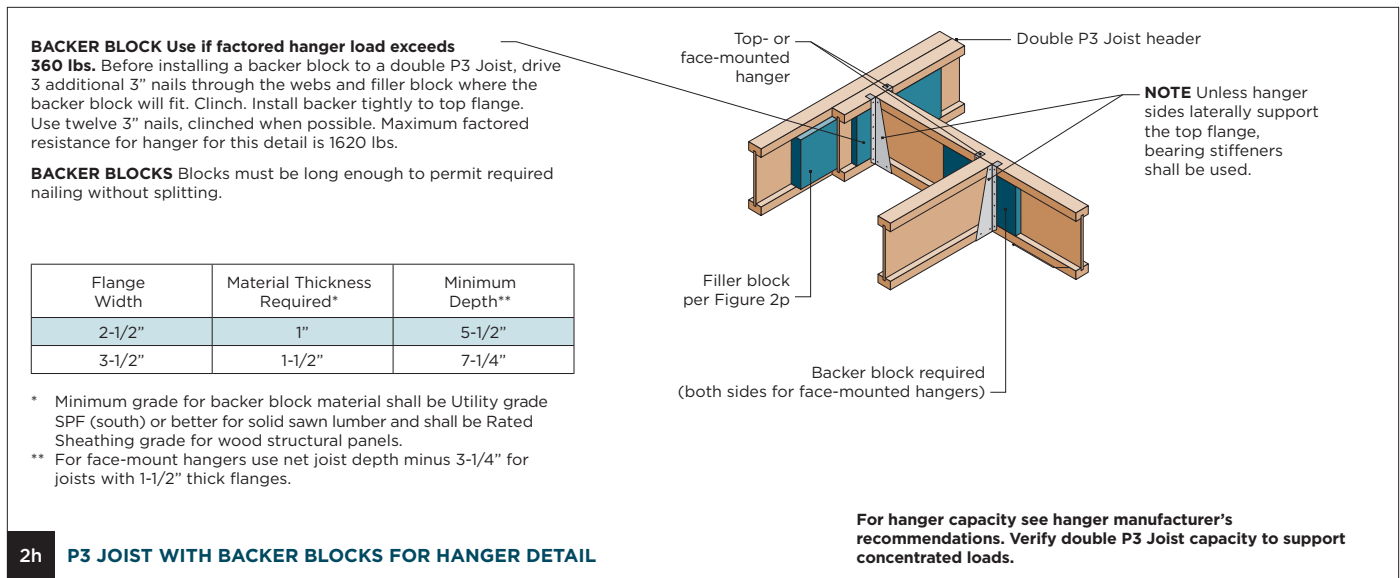

2h P3 JOIST WITH BACKER BLOCKS FOR HANGER DETAIL

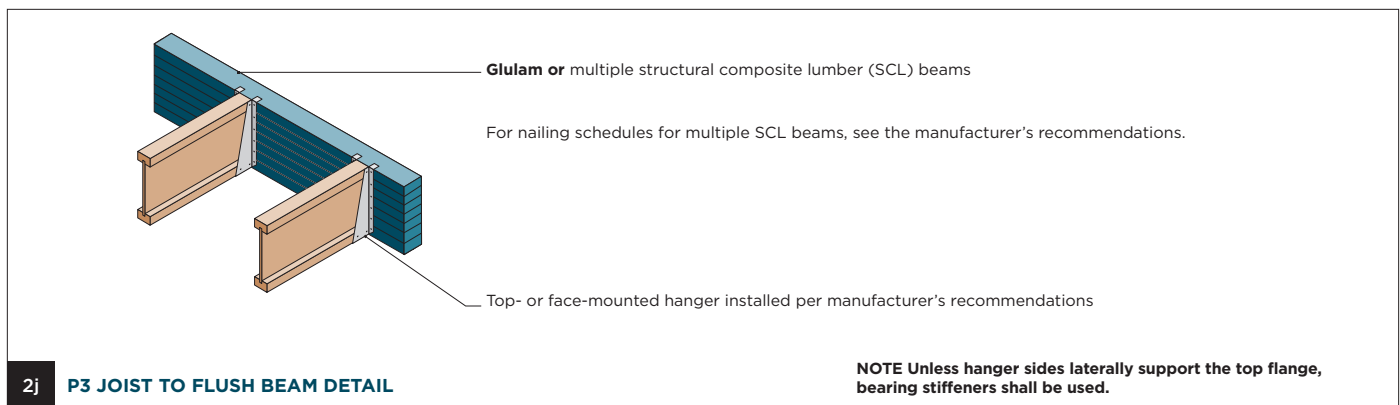

2j P3 JOIST TO FLUSH BEAM DETAIL

FIGURE 2 (CONTINUED)

Typical P3 Floor Joist Framing and Construction Details

All nails shown in the details below are assumed to be common nails unless otherwise noted. Framing lumber is assumed to be Spruce-Pine-Fir. Individual components are not shown to scale for clarity.

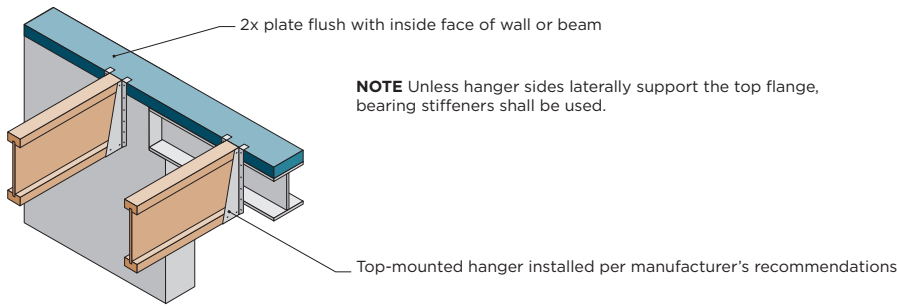

2k P3 JOIST WITH TOP MOUNT HANGER DETAIL

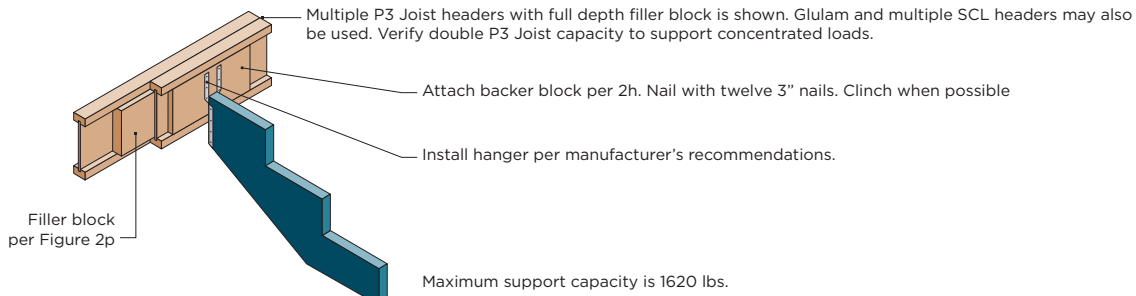

2m STAIR STRINGER TO P3 JOIST DETAIL

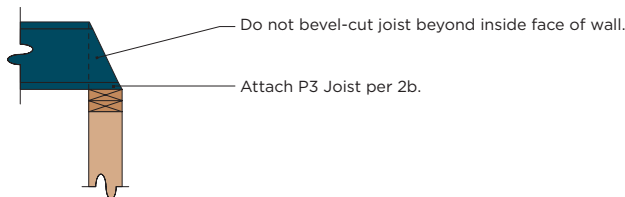

2n BEVEL-CUT P3 JOIST DETAIL

NOTE Blocking is required at bearing for lateral support. Not shown for clarity

Flange Width	Net Depth	Filler Block Size
2-1/2"	9-1/2"	2-1/8" x 6"
	11-7/8"	2-1/8" x 8"
	14"	2-1/8" x 10"
	16"	2-1/8" x 12"
3-1/2"	11-7/8"	3" x 8"
	14"	3" x 10"
	16"	3" x 12"
3-1/2"	18"	3" x 14"
	20"	3" x 16"
	24"	3" x 20"

NOTES

1. Support back of I-Joist web during nailing to prevent damage to web/flange connection.
2. Leave a 1/8" gap between top of filler block and bottom of top P3 Joist flange.
3. Filler block is required between joists for full length of span.
4. Nail joists together with two rows of 3" nails at 12" o.c. (clinched when possible) on each side of the double P3 Joist. Total of 4 nails per foot required. If nails can be clinched, only 2 nails per foot are required.
5. The maximum load that may be applied to one side of the double joist using this detail is 860 lbs./ft.

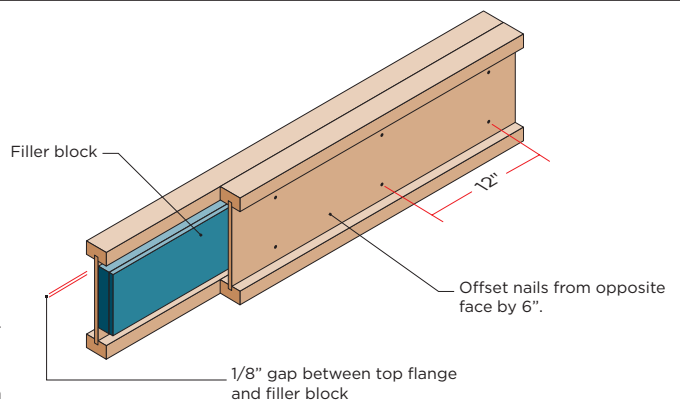

2p DOUBLE P3 JOIST CONSTRUCTION DETAIL

Web Stiffener Installation Details

FIGURE 2W

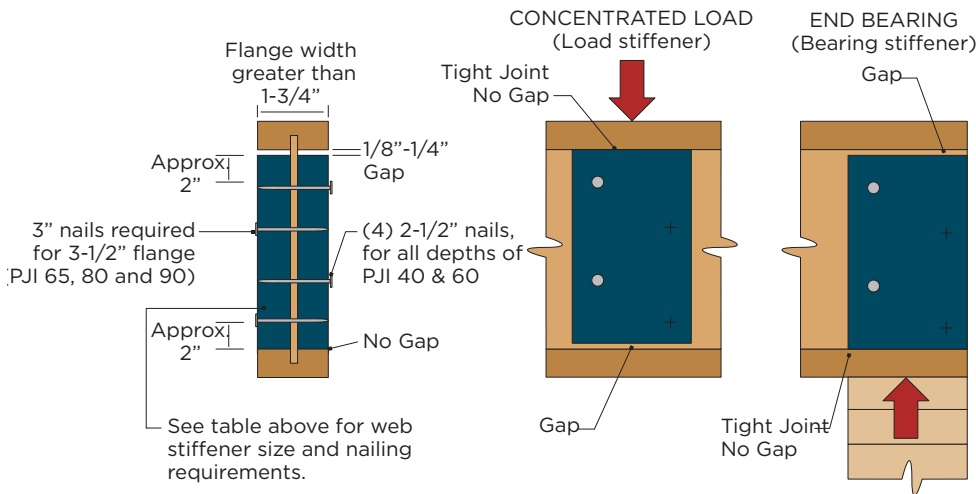

Minimum Nailing Requirements for Web Stiffeners

Stiffener Size and Nailing Requirement

Joist Dept	2-1/2" Wide Flange 8d (2-1/2") nails	3-1/2" Wide Flange 10d (3") nails
9-1/2"	4	-
11-7/8"	4	4
14"	4	4
16"	4	4
18"	-	6
20"	-	6
22"	-	8
24"	-	8
Minimum Stiffener	1" x 2-5/16" (width)	1-1/2" x 2-5/16" (width)

- Web stiffeners are required:
 - When sides of the hangers do not laterally brace the top flange of each P3 Joist;
 - When P3 Joists are designed to support concentrated loads greater than 1500 lbs. that are applied to the P3 Joist's top flange between supports. In these applications only, the gap between the web stiffener and the flange shall be at the bottom flange;
 - For all engineered applications with end-reactions greater than 1500 lbs. **A design analysis must be performed for all engineered applications with end-reactions greater than 1500 lbs.**
- When used at end bearings, install web stiffeners tightly against the bottom flange of the P3 Joist. Leave a minimum 1/8" gap between the top of the stiffener and the bottom of the top flange. See Figure 2W.
- Web stiffeners may be supplied by the distributor for field installation or may be cut in the field as required.

Cantilever Details for Interior Balconies (No Wall Load)

FIGURE 3

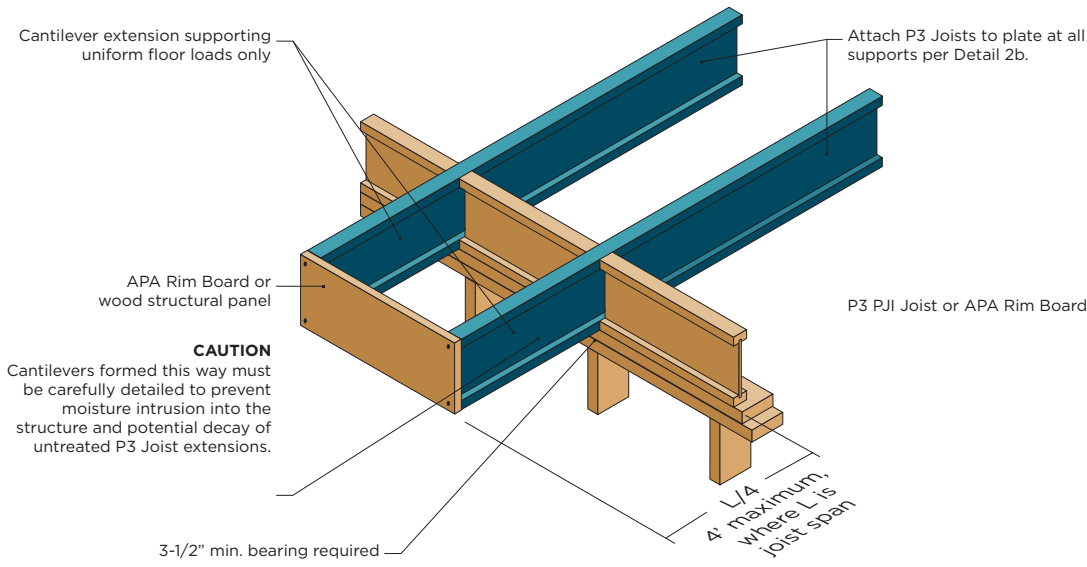

Lumber Cantilever Details For Balconies (No Wall Load)

FIGURE 4

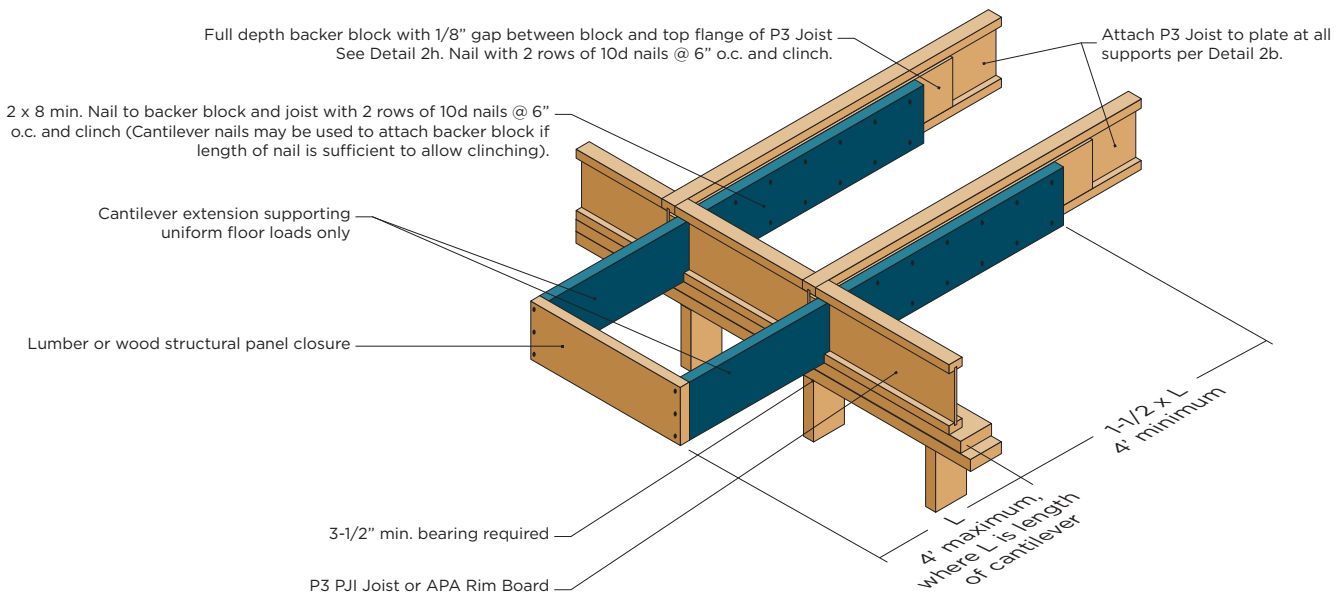

NOTES All nails shown in the details above are assumed to be common nails unless otherwise noted. Individual components are not shown to scale for clarity.

Cantilever Detail for Vertical Building Offset (Concentrated Wall Load)

FIGURE 5A

Method 1

Sheathing Reinforcement One Side

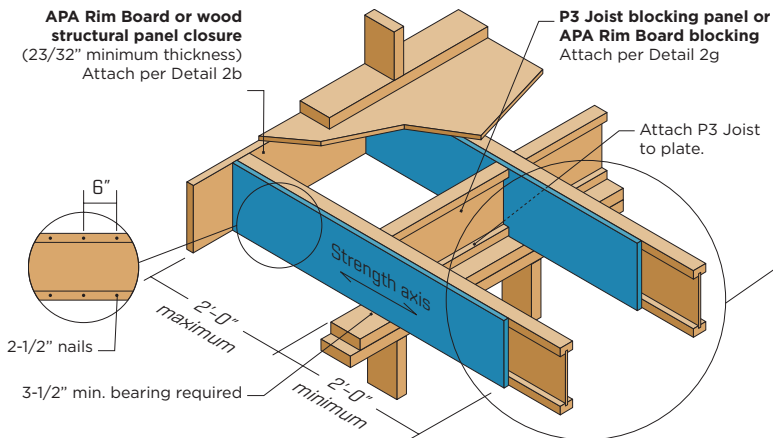

Method 2

Sheathing Reinforcement Two Sides

Use same installation as Method 1, but reinforce both sides of the P3 Joist with sheathing or APA Rim Board.

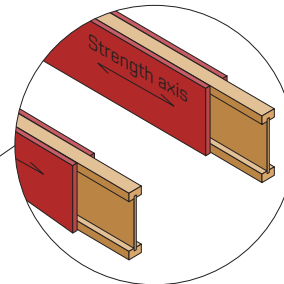

Use nailing pattern shown for Method 1 with opposite face nailing offset by 3".

NOTE APA RATED SHEATHING 48/24 (minimum thickness 23/32") required on sides of joist. Depth shall match the full height of the joist. Nail top and bottom flange with 2-1/2" nails at 6" o.c. Install with face grain running horizontally. Attach P3 Joist to plate at all supports per Detail 2b.

FIGURE 5B

Double P3 Joists

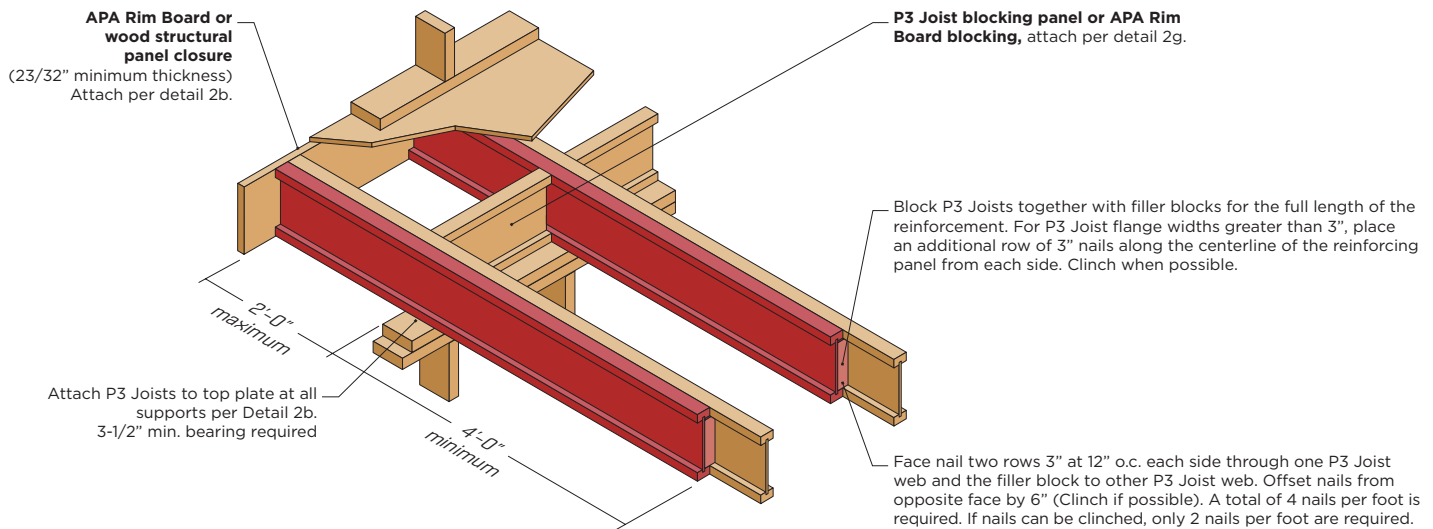

NOTES All nails shown in the details above are assumed to be common nails unless otherwise noted. Individual components are not shown to scale for clarity.

Cantilever Details for Vertical Building Offset (Concentrated Wall Load)

FIGURE 5C

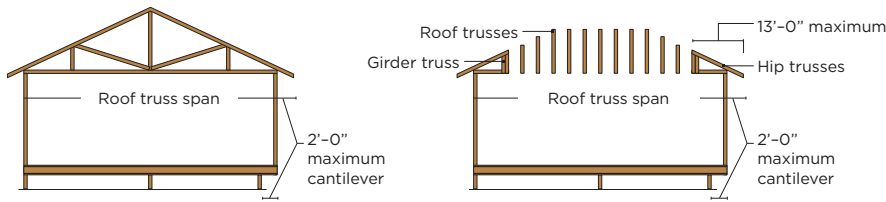

See Table below for APA PRI reinforcement requirements at cantilever.

For hip roofs with the hip trusses running parallel to the cantilevered floor joists, the P3 Joists reinforcement requirements for a span of 26 ft. shall be permitted to be used.

Source: APA

Cantilever Reinforcement Methods

TABLE 7
P3 Joist Cantilever Reinforcement Methods Allowed

Joist Depth (in.)	Roof Truss Span (ft)	ROOF LOADINGS											
		TL = 35 psf LL not to exceed 20 psf Joist Spacing (in.)				TL = 45 psf LL not to exceed 30 psf Joist Spacing (in.)				TL = 55 psf LL not to exceed 40 psf Joist Spacing (in.)			
		12	16	19.2	24	12	16	19.2	24	12	16	19.2	24
9-1/2	26	N	N	N	1, 2	N	N	1, 2	2	N	1, 2	2	X
	28	N	N	1, 2	1, 2	N	N	1, 2	2	N	1, 2	2	X
	30	N	N	2	1, 2	N	1, 2	1, 2	2	N	1, 2	2	X
	32	N	N	1, 2	2	N	1, 2	1, 2	X	N	1, 2	2	X
	34	N	N	1, 2	2	N	1, 2	2	X	N	2	X	X
36	N	N	1, 2	2	N	1, 2	2	X	N	2	X	X	
11-7/8	26	N	N	N	1, 2	N	N	1, 2	1, 2	N	1, 2	1, 2	2
	28	N	N	1, 2	1, 2	N	1, 2	1, 2	1, 2	N	1, 2	1, 2	2
	30	N	N	1, 2	1, 2	N	1, 2	1, 2	2	N	1, 2	1, 2	2
	32	N	N	1, 2	1, 2	N	1, 2	1, 2	2	N	1, 2	1, 2	2
	34	N	N	1, 2	1, 2	N	1, 2	1, 2	2	N	1, 2	2	2
	36	N	N	1, 2	1, 2	N	1, 2	1, 2	2	N	1, 2	2	2
38	N	1, 2	1, 2	2	N	1, 2	1, 2	2	1, 2	1, 2	2	X	
14	26	N	N	N	1, 2	N	N	N	1, 2	N	N	1, 2	1, 2
	28	N	N	N	1, 2	N	N	1, 2	1, 2	N	N	1, 2	2
	30	N	N	N	1, 2	N	N	1, 2	1, 2	N	1, 2	1, 2	2
	32	N	N	N	1, 2	N	N	1, 2	1, 2	N	1, 2	1, 2	2
	34	N	N	N	1, 2	N	N	1, 2	2	N	1, 2	1, 2	2
	36	N	N	1, 2	1, 2	N	1, 2	1, 2	2	N	1, 2	1, 2	2
	38	N	N	1, 2	1, 2	N	1, 2	1, 2	2	N	1, 2	1, 2	2
40	N	N	1, 2	1, 2	N	1, 2	1, 2	2	N	1, 2	2	2	
16	26	N	N	N	1, 2	N	N	1, 2	1, 2	N	N	1, 2	1, 2
	28	N	N	N	1, 2	N	N	1, 2	1, 2	N	1, 2	1, 2	2
	30	N	N	N	1, 2	N	N	1, 2	1, 2	N	1, 2	1, 2	2
	32	N	N	N	1, 2	N	N	1, 2	1, 2	N	1, 2	1, 2	2
	34	N	N	1, 2	1, 2	N	N	1, 2	2	N	1, 2	1, 2	2
	36	N	N	1, 2	1, 2	N	1, 2	1, 2	2	N	1, 2	1, 2	2
	38	N	N	1, 2	1, 2	N	1, 2	1, 2	2	N	1, 2	2	2
	40	N	N	1, 2	1, 2	N	1, 2	1, 2	2	N	1, 2	2	2
42	N	N	1, 2	1, 2	N	1, 2	1, 2	2	N	1, 2	2	X	

NOTES

- N = No reinforcement required
 1 = P3 Joists reinforced with 23/32" wood structural panel on one side only
 2 = P3 Joists reinforced with 23/32" wood structural panel on both sides or double P3 Joist
 X = Try a deeper joist or closer spacing.
- Color coding in table is matched to details in Figures 5a and 5b.
- Maximum load shall be 15 psf roof dead load, 50 psf floor total load, and 80 plf wall load. Wall load is based on 3'-0" maximum width window or door openings. For larger openings or multiple 3'-0" width openings spaced less than 6'-0" o.c., additional joists beneath the opening's cripple studs may be required.
- Table applies to joists 12" to 24" o.c. Use 12" o.c. requirements for lesser spacings.
- For conventional roof construction using a ridge beam, the Roof Truss Span column above is equivalent to the distance between the supporting wall and the ridge beam. When the roof is framed using a ridge board, the Roof Truss Span is equivalent to the distance between the supporting walls as if a truss is used.
- Cantilevered joists supporting girder trusses or roof beams may require additional reinforcing.

Typical Floor Framing Installation Notes

1. Installation of P3 Joist shall be in accordance with Figure 2.
2. Except for cutting joist to length, P3 Joist flanges should **NEVER** be cut, drilled, or notched.
3. Concentrated loads should be applied only to the top surface of the top flange. At no time should concentrated loads be suspended from the bottom flange with the exception of light loads such as ceiling fans, light fixtures, etc.
4. P3 Joists must be protected from the weather prior to installation.
5. P3 Joists must not be used in applications where they will be permanently exposed to weather or will reach a moisture content greater than 16% such as in swimming pool or hot tub areas. They must not be installed where they will remain in direct contact with concrete or masonry.
6. End-bearing length must be at least 1-3/4". For multiple span joists, intermediate bearing length must be at least 3-1/2".
7. Ends of floor joists shall be restrained to prevent rollover. Use Certified Rim Board or P3 Joist blocking panels.
8. P3 Joists installed beneath bearing walls perpendicular to the joists require full depth blocking panels, Certified Rim Board, or squash blocks (cripple blocks) in order to transfer gravity loads from above the floor system to the wall or foundation below. See note 2g page 14.
9. For P3 Joists up to 18" deep installed as rim board directly beneath bearing walls parallel to the joists, the maximum factored vertical load using a single P3 Joist is 2900 plf and is 5800 plf if double P3 Joists are used. Full bearing is required under P3 Joist used as rim board.
10. Continuous lateral support of the P3 Joist's compression flange is required to prevent rotation and buckling. In simple span uses, lateral support of the top flange is normally supplied by the floor sheathing. In multiple span or cantilever applications, bracing of the P3 Joist's bottom flange is also required at interior supports of multiple-span joists and at the end support next to the cantilever extension. The ends of all cantilever extensions must be laterally braced as shown in Figure 3 or 4.
11. Nails installed perpendicular to the wide face of the flange shall be spaced in accordance with the applicable building code requirements or approved building plans but should not be closer than 2" o.c. per row.
12. Figure 2 details show only P3 Joist-specific fastener requirements. For other fastener requirements, see the applicable building code.
13. For Fire-Resistance ratings, typical Sound Transmission Class (STC), and typical Impact Insulation Class (IIC), refer to National Building Code of Canada 2015 Table A-9.10.3.1.B. assembly numbers F3 to F21.

Web Hole Rules and Specifications

One of the benefits of using P3 Joists in residential floor construction is that holes may be cut in the joist webs to accommodate electrical wiring, plumbing lines, and other mechanical systems, thereby minimizing the depth of the floor system.

Rules for Cutting Holes in P3 Joist

1. The distance between the inside edge of the support and the center line of any hole shall be in compliance with the requirements of Table 9.
2. P3 Joist top and bottom flanges must **NEVER** be cut, notched, or otherwise modified.
3. Whenever possible field-cut holes should be centered on the middle of the web.
4. The maximum size hole that can be cut into a P3 Joist web shall equal the clear distance between the flanges of the P3 Joist minus 1/4". A minimum of 1/8" should always be maintained between the top or bottom of the hole and the adjacent P3 Joist flange.
5. The sides of square holes or longest sides of rectangular holes should not exceed three-fourths of the diameter of the maximum round hole permitted at that location.
6. Where more than one hole is necessary, the distance between adjacent hole edges shall exceed twice the diameter of the largest round hole or twice the size of the largest square hole **(or twice the length of the longest side of the longest rectangular hole)** and each hole must be sized and located in compliance with the requirements of Table 9.
7. Holes measuring 1-1/2" shall be permitted anywhere in a cantilevered section of a P3 Joist. Holes of greater size may be permitted subject to verification.
8. A 1-1/2" hole can be placed anywhere in the web provided that it meets the requirements of rule 6 above.
9. All holes shall be cut in a workman-like manner in accordance with the restrictions listed above and as illustrated in Figure 6.
10. Limit of 3 maximum size holes per span.
11. A group of round holes at approximately the same location shall be permitted if they meet the requirements for a single round hole circumscribed around them.

P3 Joist Typical Holes

FIGURE 6

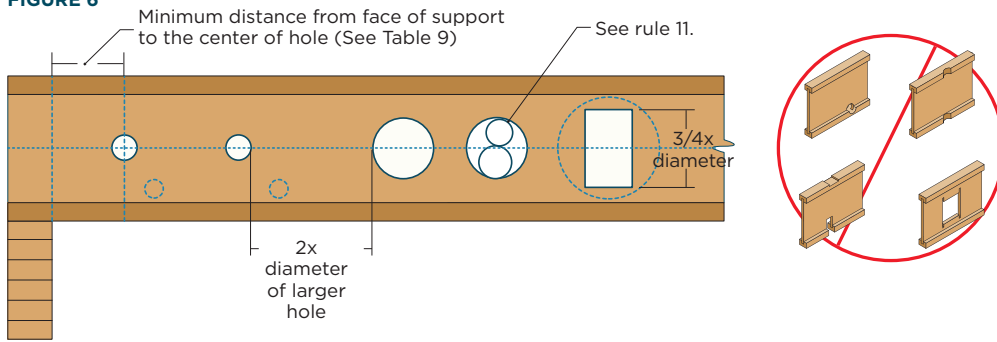

Cutting the Holes

- **Never** drill, cut, or notch the flange. **Never** over-cut the web.
- Holes in webs should be cut with a sharp saw.
- For rectangular holes avoid over cutting the corners as this can cause unnecessary stress concentrations. Slightly rounding the corners is recommended. Starting the rectangular hole by drilling a 1" diameter hole in each of the 4 corners and then making the cuts between the holes is another good method to minimize damage to I-Joist.

TABLE 9

Location Of Circular Holes In P3 Joist Webs

Simple or Multiple Spans for Dead Loads up to 15 psf and Live Loads up to 40 psf1,2,3,4

Joist Depth	Joist	Minimum Distance from Inside Face of Any Support to Center of Hole [ft-in]															
		Round Hole Diameter (in)															
		SAF(5)	2	3	4	5	6	6 1/4	7	8	8 5/8	9	10	10 3/4	11	12	12 3/4
9.5	PJI-40	14-2"	0'-7"	0'-8"	1'-5"	3'-0"	4'-8"	5'-2"	-	-	-	-	-	-	-	-	-
	PJI-60	15-3"	0'-7"	0'-8"	1'-8"	3'-3"	5'-0"	5'-5"	-	-	-	-	-	-	-	-	-
	PJI-80	15-6"	0'-7"	0'-8"	2'-2"	3'-10"	5'-7"	6'-0"	-	-	-	-	-	-	-	-	-
11.875	PJI-40	16-0"	0'-7"	0'-8"	0'-8"	1'-3"	2'-8"	3'-1"	4'-2"	5'-10"	6'-11"	-	-	-	-	-	-
	PJI-60	16-6"	0'-7"	0'-8"	0'-8"	1'-7"	3'-0"	3'-5"	4'-7"	6'-2"	7'-3"	-	-	-	-	-	-
	PJI-65	16-11"	0'-7"	0'-8"	0'-8"	1'-10"	3'-3"	3'-8"	4'-10"	6'-6"	7'-7"	-	-	-	-	-	-
	PJI-80	17-5"	0'-7"	0'-8"	0'-8"	2'-0"	3'-6"	3'-11"	5'-1"	6'-10"	7'-11"	-	-	-	-	-	-
	PJI-90	17-8"	0'-7"	0'-8"	0'-10"	2'-3"	3'-9"	4'-2"	5'-4"	8'-2"	-	-	-	-	-	-	-
14	PJI-40	17-5"	0'-7"	0'-8"	0'-8"	0'-9"	1'-2"	1'-6"	2'-7"	4'-0"	4'-11"	5'-5"	7'-1"	8'-4"	-	-	-
	PJI-60	17-11"	0'-7"	0'-8"	0'-8"	0'-9"	1'-8"	2'-0"	3'-0"	4'-5"	5'-5"	6'-0"	7'-7"	8'-11"	-	-	-
	PJI-65	18-5"	0'-7"	0'-8"	0'-8"	0'-9"	2'-0"	2'-4"	3'-4"	4'-10"	5'-9"	6'-4"	8'-0"	-	-	-	-
	PJI-80	19-2"	0'-7"	0'-8"	0'-8"	0'-10"	2'-2"	2'-6"	3'-7"	5'-1"	6'-8"	8'-4"	-	-	-	-	-
	PJI-90	18-6"	0'-7"	0'-8"	0'-8"	1'-1"	2'-5"	2'-9"	3'-10"	5'-4"	6'-4"	6'-11"	8'-8"	-	-	-	-
16	PJI-40	18-8"	0'-7"	0'-8"	0'-8"	0'-9"	0'-9"	0'-10"	1'-4"	2'-7"	3'-5"	4'-0"	5'-5"	6'-6"	6'-11"	8'-6"	-
	PJI-60	19-7"	0'-7"	0'-8"	0'-8"	0'-9"	0'-9"	0'-10"	1'-10"	3'-2"	4'-0"	4'-6"	5'-11"	7'-1"	7'-6"	9'-1"	-
	PJI-65	20-0"	0'-7"	0'-8"	0'-8"	0'-9"	0'-11"	1'-2"	2'-2"	3'-6"	4'-4"	4'-11"	6'-4"	7'-6"	7'-10"	9'-6"	-
	PJI-80	20-10"	0'-7"	0'-8"	0'-8"	0'-9"	1'-0"	1'-4"	2'-4"	3'-8"	4'-7"	5'-2"	6'-8"	7'-10"	8'-3"	9'-11"	-
18	PJI-40	21-3"	0'-7"	0'-8"	0'-8"	0'-9"	1'-3"	1'-7"	2'-7"	4'-0"	4'-10"	5'-5"	6'-11"	8'-1"	8'-6"	10'-3"	-
	PJI-80	22-5"	0'-7"	0'-8"	0'-8"	0'-9"	0'-9"	0'-10"	0'-10"	1'-4"	2'-3"	2'-9"	4'-3"	5'-4"	5'-9"	7'-4"	8'-7"
	PJI-90	22-10"	0'-7"	0'-8"	0'-8"	0'-9"	0'-9"	0'-10"	0'-10"	1'-8"	2'-6"	3'-1"	4'-6"	5'-8"	6'-1"	7'-8"	8'-11"
	PJI-80	23-11"	0'-7"	0'-8"	0'-8"	0'-9"	0'-9"	0'-10"	0'-10"	0'-10"	1'-5"	1'-11"	3'-3"	4'-4"	4'-8"	6'-1"	7'-2"
20	PJI-90	24-4"	0'-7"	0'-8"	0'-8"	0'-9"	0'-9"	0'-10"	0'-10"	0'-11"	1'-9"	2'-3"	3'-7"	4'-8"	5'-0"	6'-5"	7'-6"
	PJI-80	25-6"	0'-7"	0'-8"	0'-8"	0'-9"	0'-9"	0'-10"	0'-10"	0'-10"	0'-11"	0'-11"	0'-11"	0'-12"	1'-3"	2'-5"	3'-4"
24	PJI-80	27-3"	0'-7"	0'-8"	0'-8"	0'-9"	0'-9"	0'-10"	0'-10"	0'-10"	0'-11"	1'-0"	2'-2"	3'-0"	3'-4"	4'-7"	5'-6"
	PJI-90	27-3"	0'-7"	0'-8"	0'-8"	0'-9"	0'-9"	0'-10"	0'-10"	0'-10"	0'-11"	1'-0"	2'-2"	3'-0"	3'-4"	4'-7"	5'-6"

NOTES

1. Above tables may be used for P3 Joist spacing of 24" on center or less.
2. Hole location distance is measured from inside face of supports to center of hole.
3. Distances in this chart are based on uniformly loaded joists.
4. Hole sizes and/or locations that fall outside of the scope of this table may be acceptable based on analysis of actual hole size, span, spacing, and loading conditions.
5. SAF stands for Span Adjustment Factor. SAF is used as defined below.

OPTIONAL

Table 9 is based on the P3 Joist being used at their maximum span. If the P3 Joist are placed at less than their full allowable span, the maximum distance from the centerline of the hole to the face of any support (D) as given above may be reduced as follows.

$$D_{\text{reduced}} = \frac{L_{\text{actual}}}{\text{SAF}} \times D$$

Where: D_{reduced} = Distance from the inside face of any support to center of hole is reduced for less-than-maximum span applications (ft). The reduced distance shall not be less than 6" from the face of support to edge of the hole.

L_{actual} = The actual measured span distance between the inside faces of supports (ft)

SAF = Span Adjustment Factor is given in the table above.

D = The minimum distance from the inside face of any support to center of hole from Table 9 above

If $\frac{L_{\text{actual}}}{\text{SAF}}$ is greater than 1, use 1 in the above calculation

Typical P3 Joist Roof Framing and Construction Details

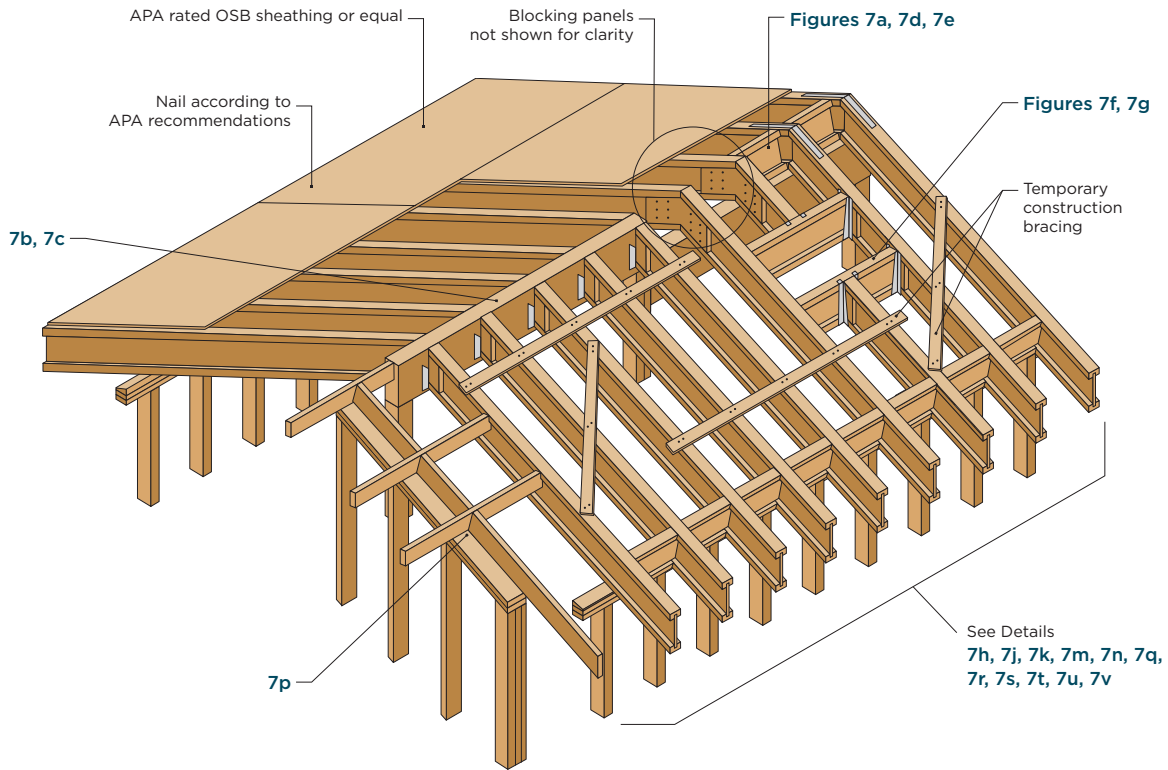

7a UPPER END, BEARING ON WALL

NOTE Additional connection may be required for wind uplift.

Source: APA

FIGURE 7 (CONTINUED)

Typical P3 Joist Roof Framing and Construction Details

All nails shown in the details below are assumed to be common nails unless otherwise noted. Framing lumber is assumed to be Spruce-Pine-Fir. Individual components are not shown to scale for clarity.

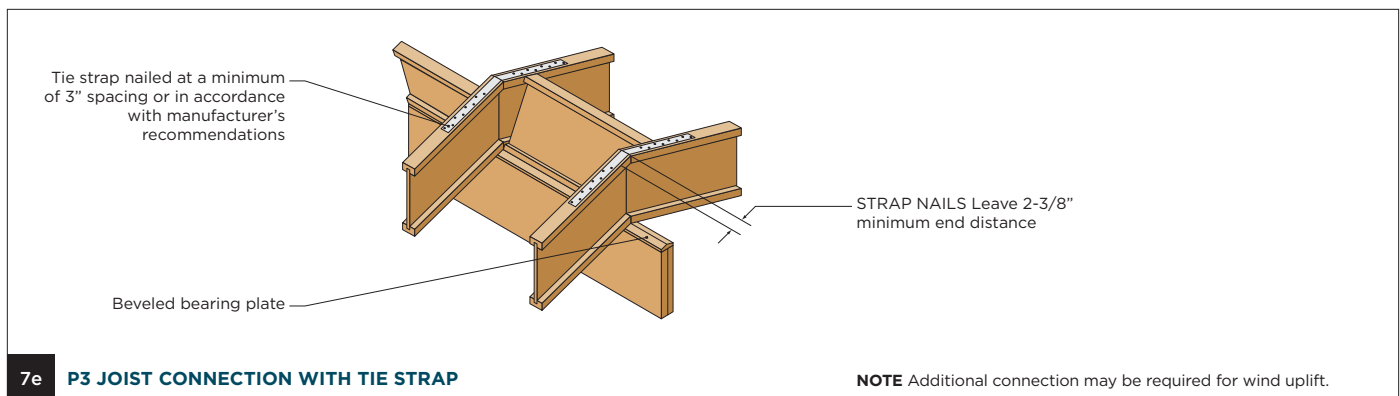
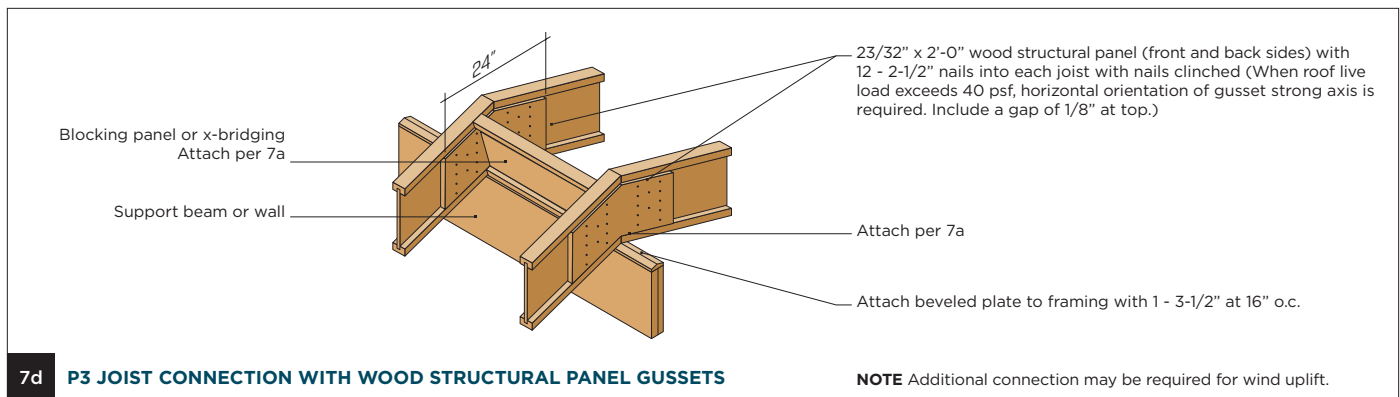
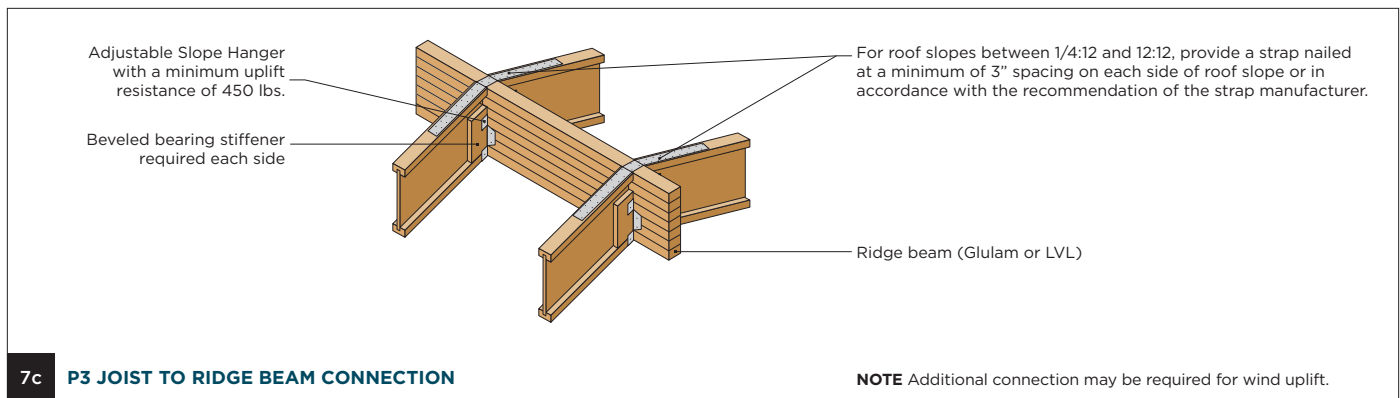
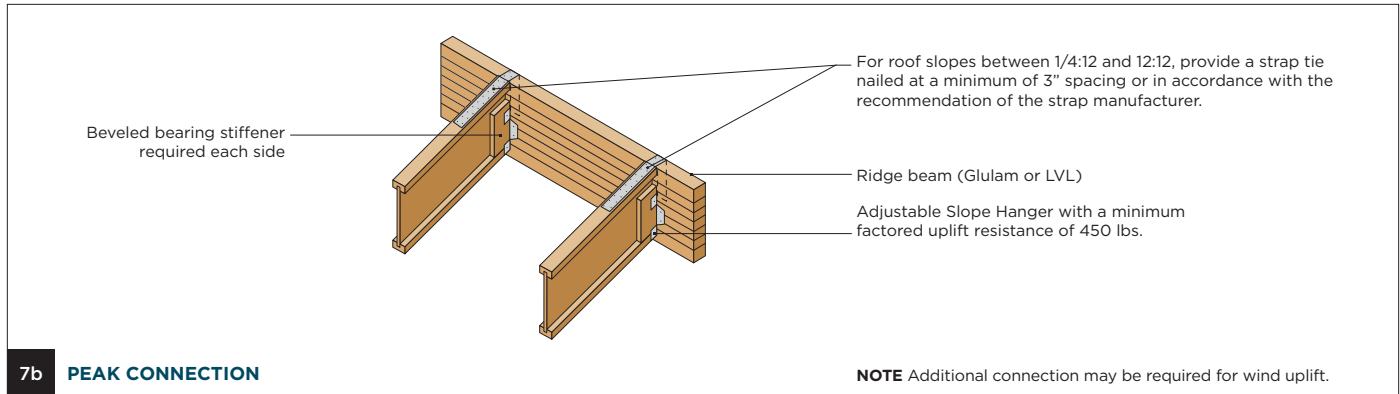

Source: APA

FIGURE 7 (CONTINUED)

Typical P3 Joist Roof Framing and Construction Details

All nails shown in the details below are assumed to be common nails unless otherwise noted. Framing lumber is assumed to be Spruce-Pine-Fir. Individual components are not shown to scale for clarity.

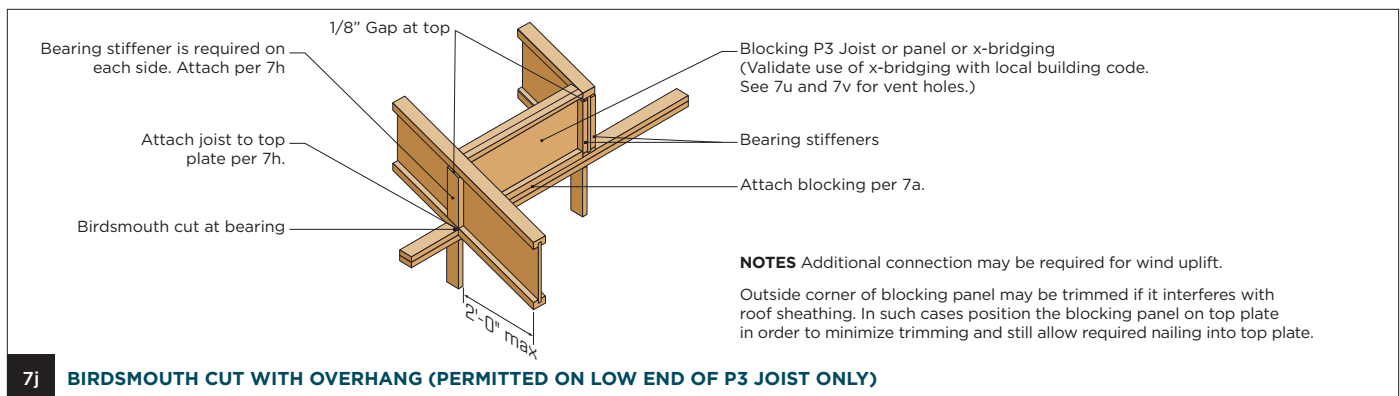
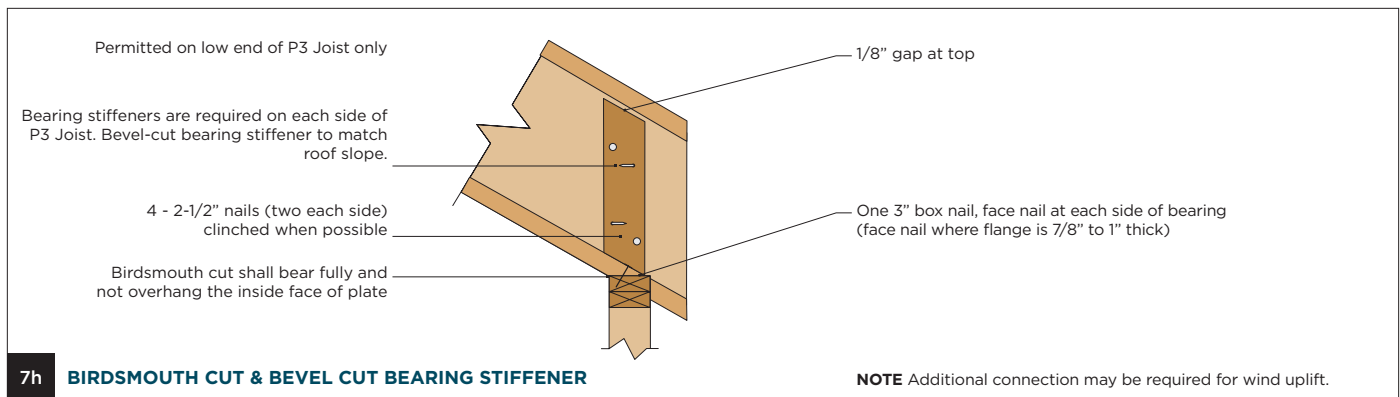
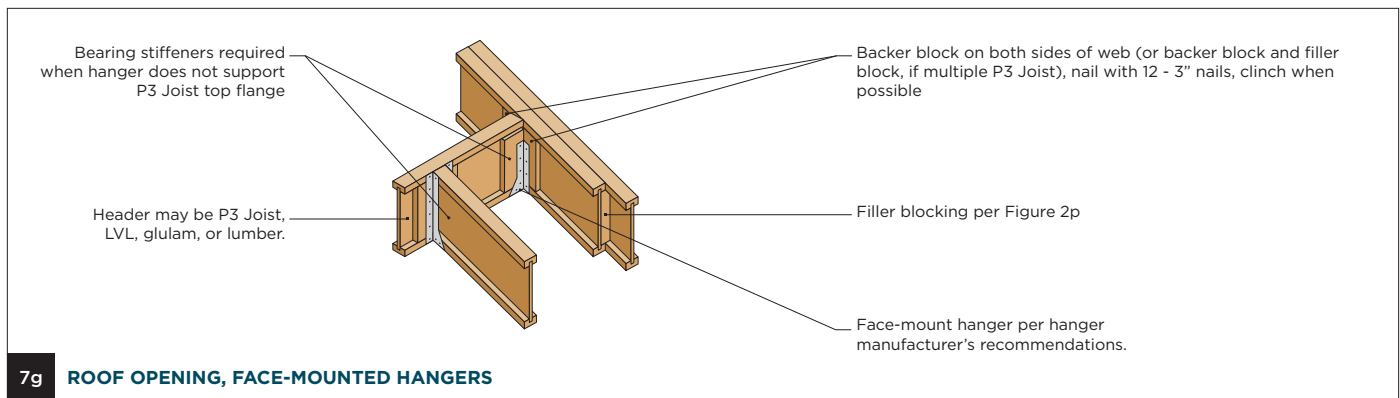
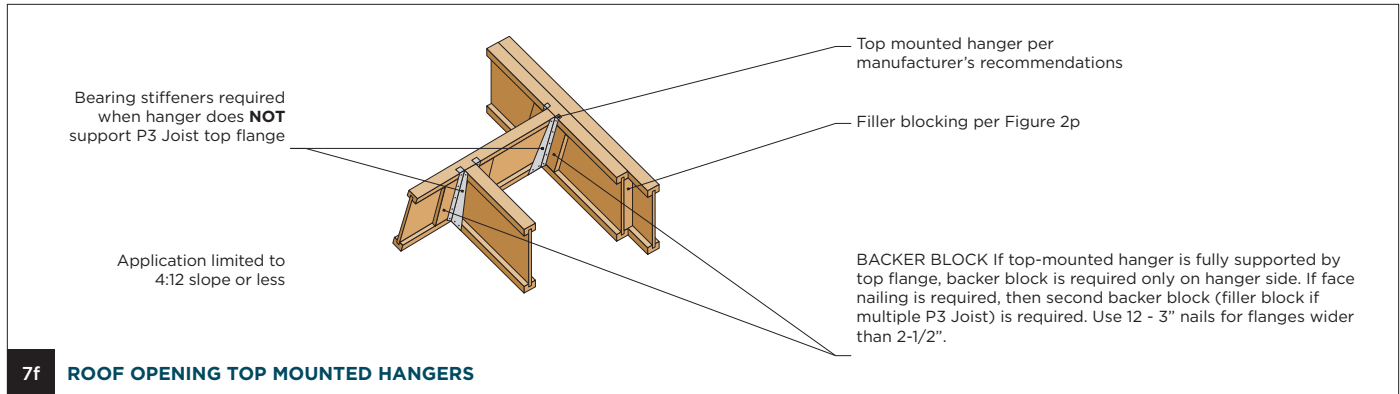

Source: APA

FIGURE 7 (CONTINUED)

Typical P3 Joist Roof Framing and Construction Details

All nails shown in the details below are assumed to be common nails unless otherwise noted. Framing lumber is assumed to be Spruce-Pine-Fir. Individual components are not shown to scale for clarity.

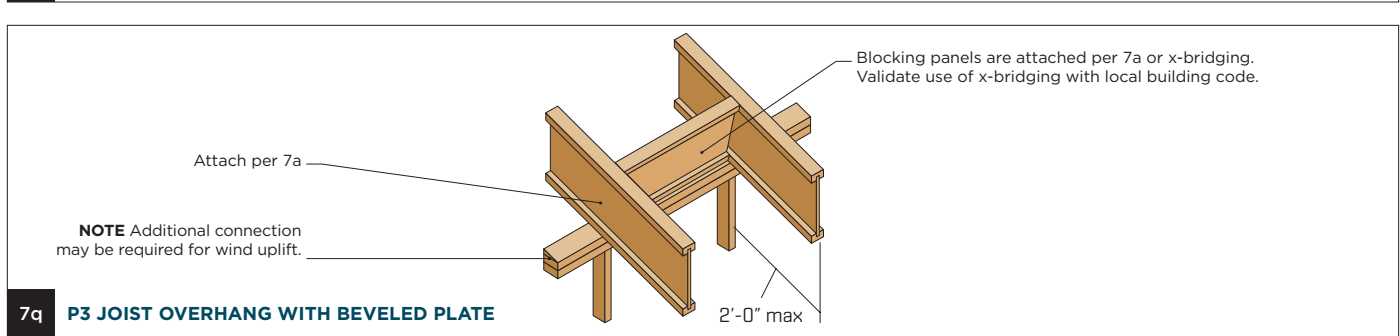
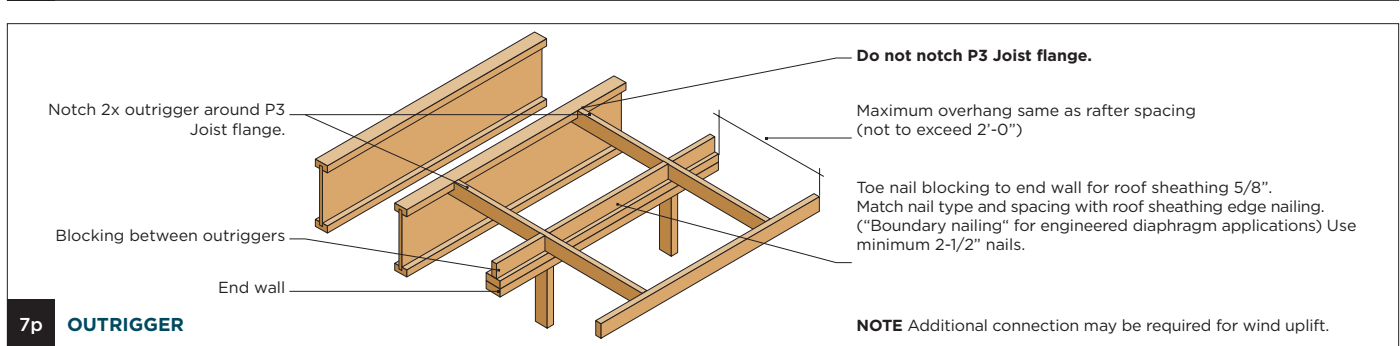
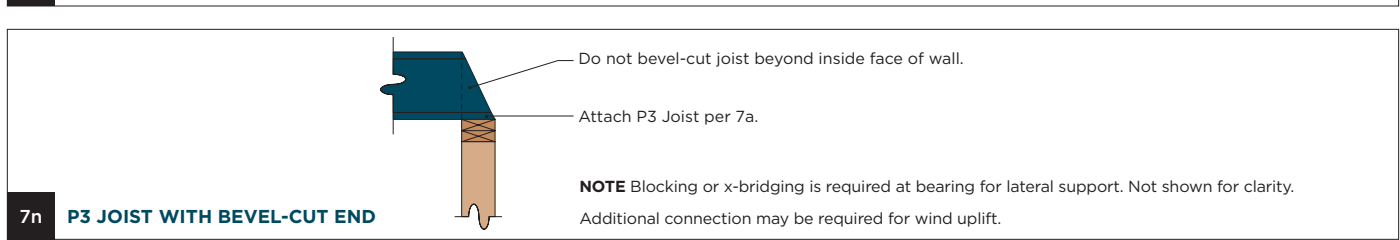
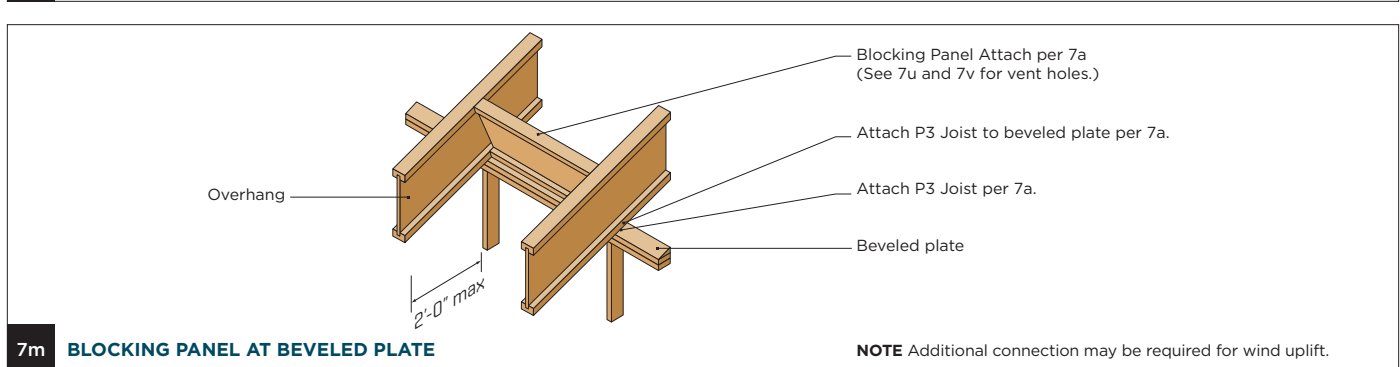
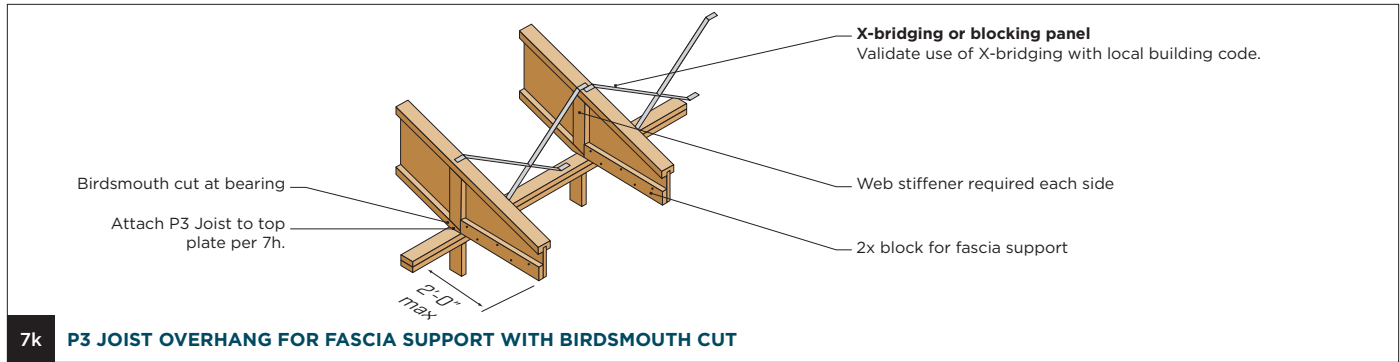

Source: APA

FIGURE 7 (CONTINUED)

Typical P3 Joist Roof Framing and Construction Details

All nails shown in the details below are assumed to be common nails unless otherwise noted. Framing lumber is assumed to be Spruce-Pine-Fir. Individual components are not shown to scale for clarity.

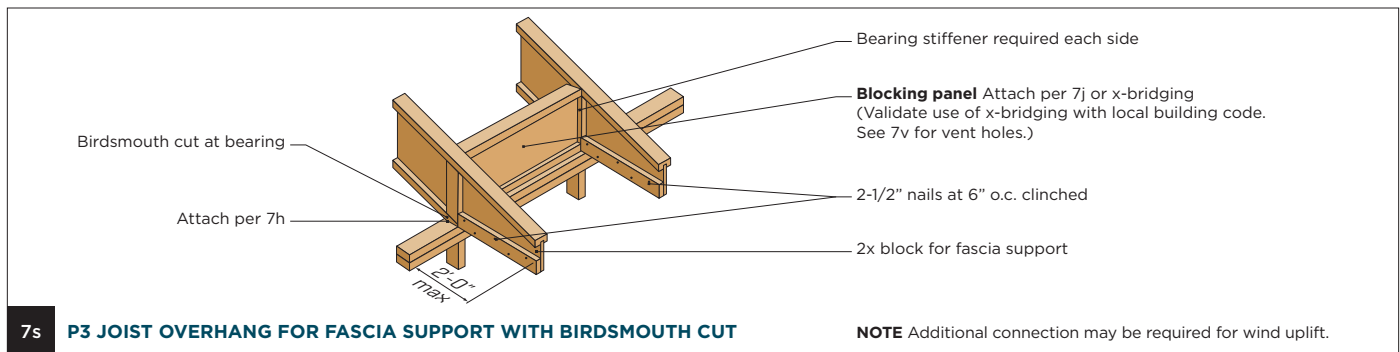
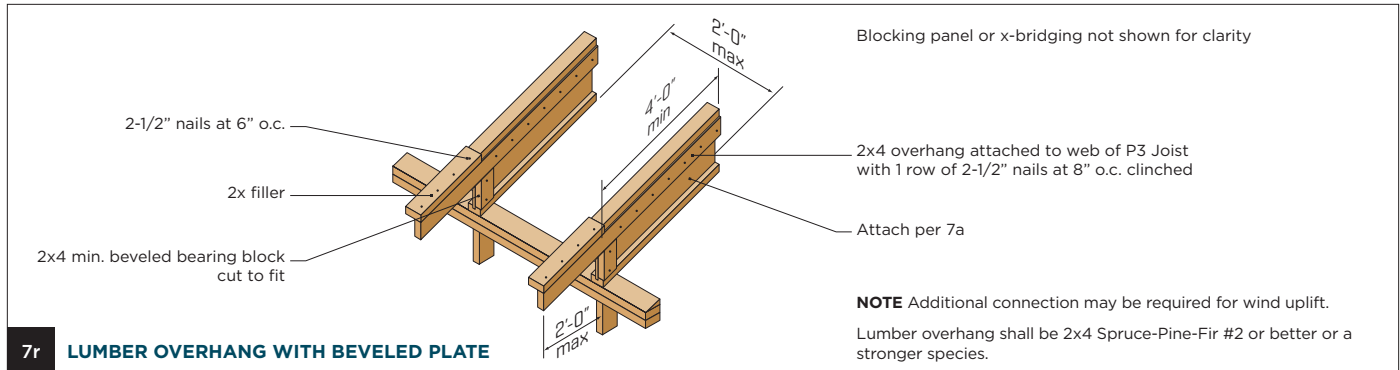

Slope Spans for Roofs

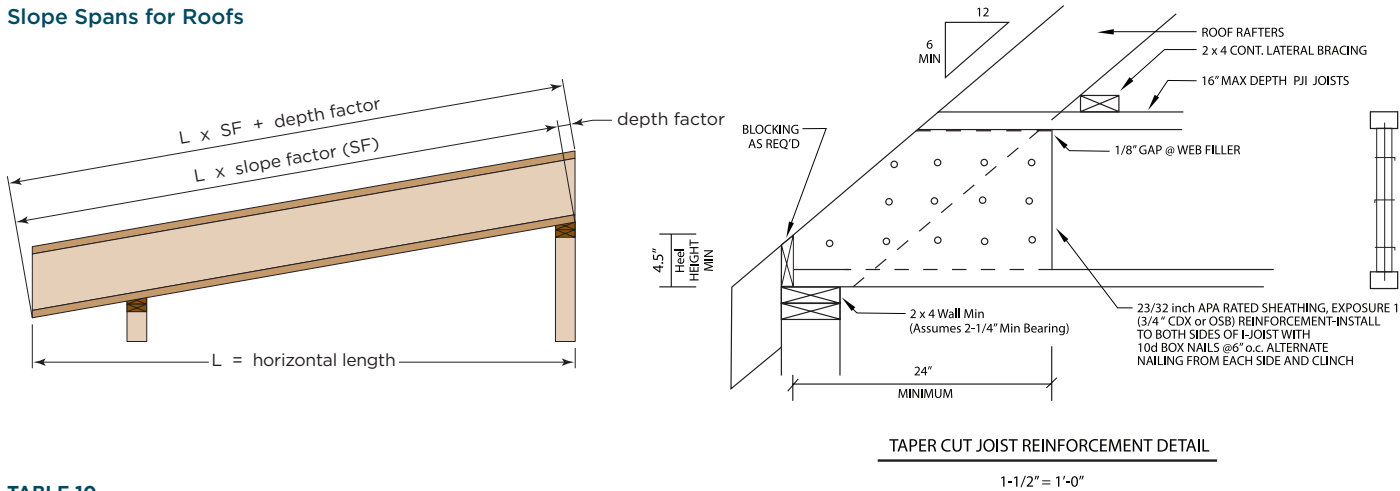

TABLE 10
Slope Factor and Depth Factor Table

Slope	2.5:12	3:12	3.5:12	4:12	4.5:12	5:12	6:12	7:12	8:12	9:12	10:12	11:12	12:12	
Slope Factor	1.021	1.031	1.042	1.054	1.068	1.083	1.118	1.158	1.202	1.250	1.302	1.357	1.414	
Depth Factor	9-1/2"	2"	2-3/8"	2-7/8"	3-1/4"	3-5/8"	4"	4-3/4"	5-5/8"	6-3/8"	7-1/4"	8"	8-3/4"	9-1/2"
	11-7/8"	2-1/2"	3"	3-1/2"	4"	4-1/2"	5"	6"	7"	8"	9"	10"	11"	11-7/8"
	14"	3"	3-1/2"	4-1/8"	4-3/4"	5-1/4"	5-7/8"	7"	8-1/4"	9-3/8"	10-1/2"	11-3/4"	12-7/8"	14"
	16"	3-3/8"	4"	4-3/4"	5-3/8"	6"	6-3/4"	8"	9-3/8"	10-3/4"	12"	13-3/8"	14-3/4"	16"
	18"	3-3/4"	4-1/2"	5-1/4"	6"	6-3/4"	7-1/2"	9"	10-1/2"	12"	13-1/2"	15"	16-1/2"	18"
	20"	4-1/4"	5"	5-7/8"	6-3/4"	7-1/2"	8-3/8"	10"	11-3/4"	13-3/8"	15"	16-3/4"	18-3/8"	20"
	22"	4-5/8"	5-1/2"	6-1/2"	7-3/8"	8-1/4"	9-1/4"	11"	12-7/8"	14-3/4"	16-1/2"	18-3/8"	20-1/4"	22"
24"	5"	6"	7"	8"	9"	10"	12"	14"	16"	18"	20"	22"	24"	

Source: APA

FIGURE 7 (CONTINUED)

Typical P3 Joist Roof Framing and Construction Details

All nails shown in the details below are assumed to be common nails unless otherwise noted. Framing lumber is assumed to be Spruce-Pine-Fir. Individual components are not shown to scale for clarity.

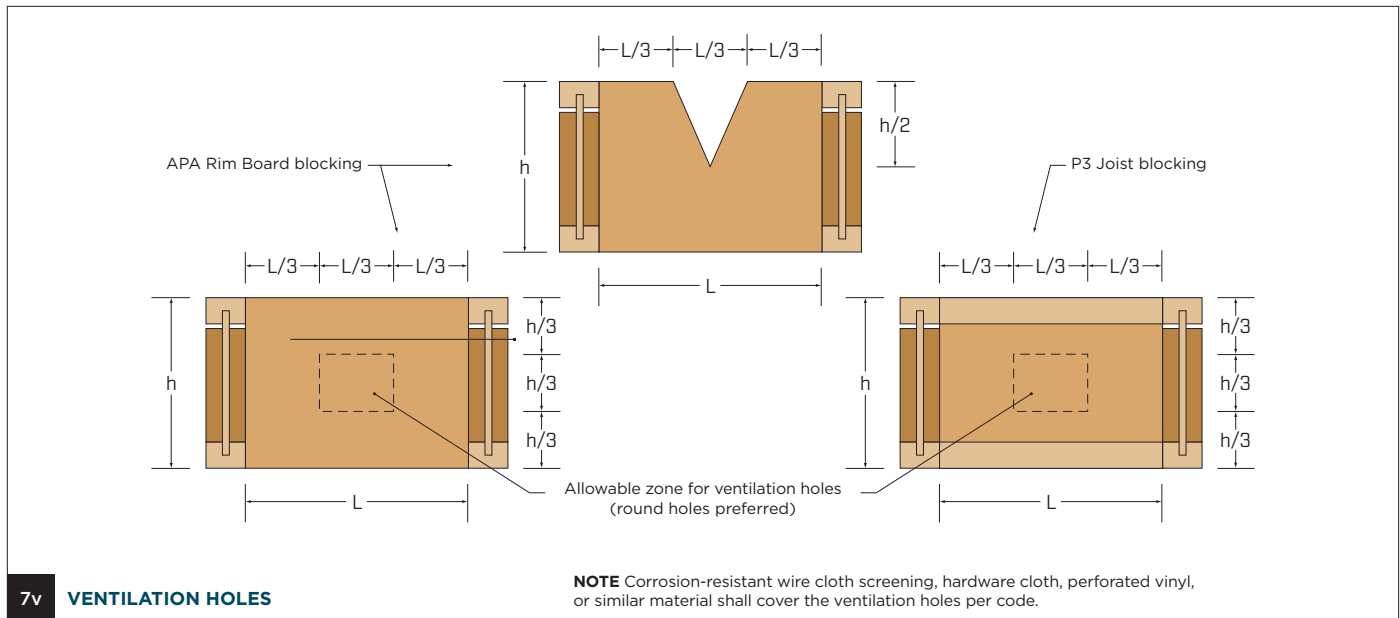
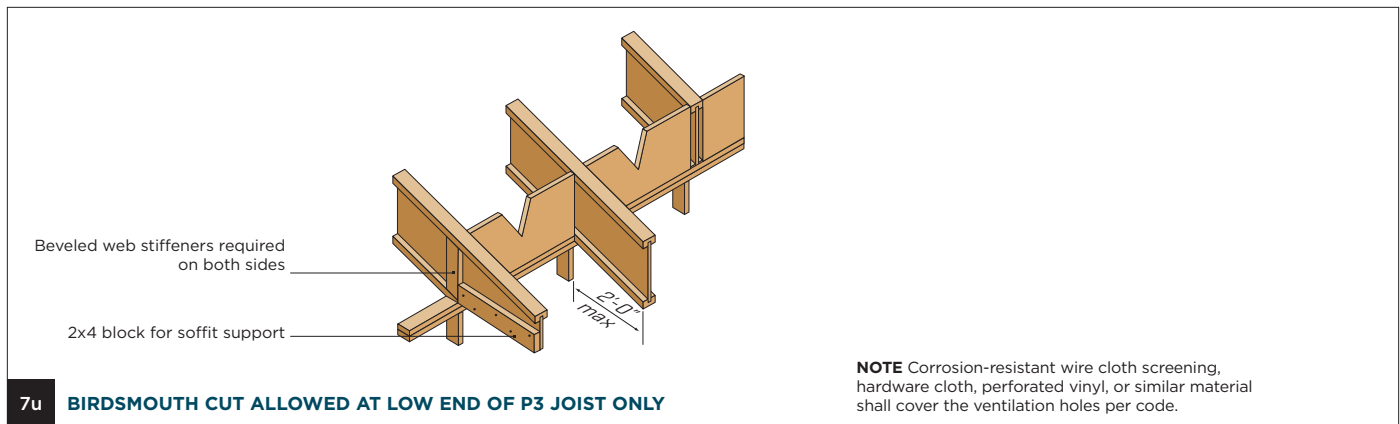
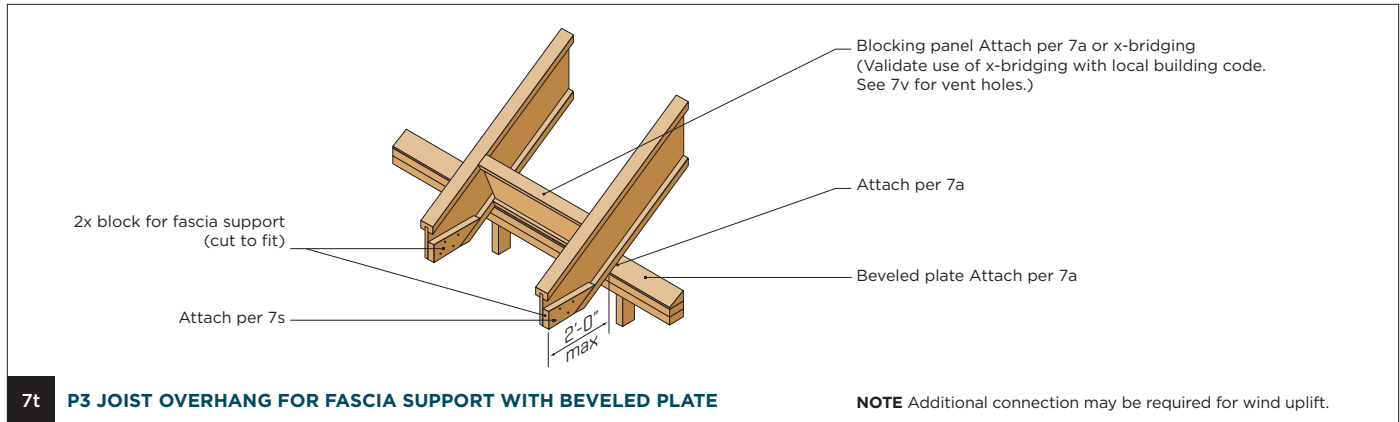

Allowable Roof Spans - Simple Span

TABLE 11
Simple Span Live Load = 20 psf Dead Load = 15 psf

Series	Depth	Slope of 1/4:12 to 4:12			Slope of 4:12 to 8:12			Slope of 8:12 to 12:12		
		16" oc	19.2" oc	24" oc	16" oc	19.2" oc	24" oc	16" oc	19.2" oc	24" oc
PJI 40	9-1/2	21'-1"	19'-10"	18'-4"	20'-3"	19'-0"	17'-7"	19'-0"	17'-10"	16'-6"
	11-7/8	25'-4"	23'-9"	21'-6"	24'-3"	22'-10"	20'-11"	22'-10"	21'-5"	19'-10"
	14	28'-9"	26'-5"	23'-8"	27'-7"	25'-9"	23'-0"	25'-11"	24'-4"	22'-2"
PJI 60	9-1/2	22'-5"	21'-1"	19'-6"	21'-6"	20'-2"	18'-8"	20'-2"	19'-0"	17'-7"
	11-7/8	26'-11"	25'-3"	23'-4"	25'-10"	24'-3"	22'-5"	24'-3"	22'-9"	21'-1"
	14	30'-8"	28'-10"	26'-8"	29'-5"	27'-7"	25'-7"	27'-7"	25'-11"	24'-0"
PJI-65	11-7/8	28'-2"	26'-5"	24'-5"	27'-0"	25'-4"	23'-6"	25'-4"	23'-10"	22'-1"
	14	32'-0"	30'-1"	27'-10"	30'-8"	28'-10"	26'-8"	28'-10"	27'-1"	25'-1"
	16	35'-6"	33'-4"	30'-2"	34'-0"	31'-11"	29'-5"	31'-11"	30'-0"	27'-10"
PJI 80	9-1/2	25'-0"	23'-6"	21'-8"	24'-0"	22'-6"	20'-10"	22'-6"	21'-2"	19'-7"
	11-7/8	29'-11"	28'-1"	26'-0"	28'-9"	27'-0"	24'-11"	27'-0"	25'-4"	23'-6"
	14	34'-1"	32'-0"	29'-7"	32'-8"	30'-8"	28'-5"	30'-8"	28'-10"	26'-8"
PJI 80ws	18	41'-3"	38'-9"	35'-10"	39'-7"	37'-2"	34'-5"	37'-2"	34'-11"	32'-4"
	20	44'-8"	41'-11"	38'-10"	42'-10"	40'-3"	37'-3"	40'-3"	37'-10"	35'-0"
	24	51'-2"	48'-1"	43'-9"	49'-1"	46'-2"	42'-7"	46'-1"	43'-4"	40'-2"
PJI 90	11-7/8	30'-11"	29'-0"	26'-10"	29'-8"	27'-10"	25'-9"	27'-10"	26'-2"	24'-2"
	14	35'-1"	32'-11"	30'-6"	33'-8"	31'-7"	29'-3"	31'-7"	29'-8"	27'-6"
	16	38'-10"	36'-6"	33'-9"	37'-3"	35'-0"	32'-5"	35'-0"	32'-11"	30'-6"
PJI 90ws	18	42'-6"	39'-11"	36'-11"	40'-9"	38'-3"	35'-5"	38'-3"	36'-0"	33'-4"
	20	46'-0"	43'-2"	40'-0"	44'-1"	41'-5"	38'-4"	41'-5"	38'-11"	36'-1"
	24	52'-9"	49'-6"	45'-10"	50'-7"	47'-6"	44'-0"	47'-6"	44'-7"	41'-4"



TABLE 12
Simple Span Live Load = 30 psf Dead Load = 15 psf

Series	Depth	Slope of 1/4:12 to 4:12			Slope of 4:12 to 8:12			Slope of 8:12 to 12:12		
		16" oc	19.2" oc	24" oc	16" oc	19.2" oc	24" oc	16" oc	19.2" oc	24" oc
PJI 40	9-1/2	18'-4"	17'-2"	15'-11"	17'-7"	16'-6"	15'-3"	16'-8"	15'-8"	14'-6"
	11-7/8	22'-0"	20'-8"	18'-10"	21'-1"	19'-10"	18'-4"	20'-0"	18'-10"	17'-5"
	14	25'-0"	23'-2"	20'-8"	24'-0"	22'-6"	20'-3"	22'-9"	21'-5"	19'-8"
PJI 60	9-1/2	19'-6"	18'-3"	16'-10"	18'-8"	17'-6"	16'-2"	17'-9"	16'-8"	15'-5"
	11-7/8	23'-4"	21'-11"	20'-3"	22'-5"	21'-0"	19'-6"	21'-3"	20'-0"	18'-6"
	14	26'-8"	25'-0"	23'-1"	25'-7"	24'-0"	22'-2"	24'-3"	22'-10"	21'-1"
PJI-65	11-7/8	24'-5"	22'-11"	21'-2"	23'-6"	22'-0"	20'-4"	22'-3"	20'-11"	19'-4"
	14	27'-10"	26'-1"	24'-1"	26'-8"	25'-1"	23'-2"	25'-4"	23'-9"	22'-0"
	16	30'-10"	28'-11"	26'-5"	29'-7"	27'-9"	25'-8"	28'-1"	26'-4"	24'-5"
PJI 80	9-1/2	21'-8"	20'-4"	18'-10"	20'-10"	19'-7"	18'-1"	19'-9"	18'-7"	17'-2"
	11-7/8	26'-0"	24'-5"	22'-6"	24'-11"	23'-5"	21'-8"	23'-8"	22'-3"	20'-7"
	14	29'-7"	27'-9"	25'-8"	28'-5"	26'-8"	24'-8"	27'-0"	25'-4"	23'-5"
PJI 80ws	18	35'-10"	33'-8"	31'-1"	34'-5"	32'-3"	29'-10"	32'-8"	30'-8"	28'-5"
	20	38'-10"	36'-5"	33'-8"	37'-3"	35'-0"	32'-4"	35'-4"	33'-3"	30'-9"
	24	44'-6"	41'-9"	38'-4"	42'-9"	40'-1"	37'-1"	40'-7"	38'-1"	35'-3"
PJI 90	11-7/8	26'-10"	25'-2"	23'-3"	25'-9"	24'-2"	22'-4"	24'-5"	22'-11"	21'-3"
	14	30'-6"	28'-7"	26'-5"	29'-3"	27'-5"	25'-5"	27'-9"	26'-1"	24'-2"
	16	33'-9"	31'-8"	29'-3"	32'-5"	30'-5"	28'-2"	30'-9"	28'-11"	26'-9"
PJI 90ws	18	36'-11"	34'-8"	32'-0"	35'-5"	33'-3"	30'-9"	33'-8"	31'-7"	29'-3"
	20	40'-0"	37'-6"	34'-8"	38'-4"	36'-0"	33'-4"	36'-5"	34'-3"	31'-8"
	24	45'-10"	43'-0"	39'-9"	44'-0"	41'-3"	38'-3"	41'-9"	39'-3"	36'-4"

Allowable Roof Spans—Simple Span (continued)

TABLE 13

Simple Span Live Load = 40 psf Dead Load = 15 psf

Series	Depth	Slope of 1/4:12 to 4:12			Slope of 4:12 to 8:12			Slope of 8:12 to 12:12		
		16" oc	19.2" oc	24" oc	16" oc	19.2" oc	24" oc	16" oc	19.2" oc	24" oc
PJI 40	9-1/2	16'-7"	15'-6"	14'-4"	15'-11"	14'-11"	13'-9"	15'-1"	14'-2"	13'-1"
	11-7/8	19'-11"	18'-8"	16'-11"	19'-1"	17'-11"	16'-7"	18'-2"	17'-0"	15'-9"
	14	22'-7"	20'-10"	18'-7"	21'-9"	20'-4"	18'-4"	20'-7"	19'-4"	17'-10"
	16	24'-8"	22'-5"	20'-1"	24'-1"	22'-1"	19'-9"	22'-11"	21'-6"	19'-3"
PJI 60	9-1/2	17'-7"	16'-6"	15'-3"	16'-11"	15'-10"	14'-8"	16'-1"	15'-1"	13'-11"
	11-7/8	21'-1"	19'-10"	18'-4"	20'-3"	19'-0"	17'-7"	19'-3"	18'-1"	16'-9"
	14	24'-1"	22'-7"	20'-11"	23'-2"	21'-8"	20'-1"	22'-0"	20'-8"	19'-1"
	16	26'-10"	25'-2"	23'-3"	25'-9"	24'-2"	22'-4"	24'-5"	22'-11"	21'-3"
PJI-65	11-7/8	22'-1"	20'-9"	19'-2"	21'-3"	19'-11"	18'-5"	20'-2"	18'-11"	17'-6"
	14	25'-2"	23'-7"	21'-9"	24'-2"	22'-8"	20'-11"	22'-11"	21'-6"	19'-11"
	16	27'-11"	26'-2"	23'-10"	26'-9"	25'-1"	23'-3"	25'-5"	23'-10"	22'-1"
PJI 80	9-1/2	19'-7"	18'-4"	16'-11"	18'-10"	17'-8"	16'-4"	17'-11"	16'-10"	15'-6"
	11-7/8	23'-6"	22'-0"	20'-4"	22'-7"	21'-2"	19'-7"	21'-5"	20'-2"	18'-7"
	14	26'-9"	25'-1"	23'-2"	25'-8"	24'-1"	22'-3"	24'-5"	22'-11"	21'-2"
	16	29'-8"	27'-10"	25'-9"	28'-6"	26'-9"	24'-9"	27'-1"	25'-5"	23'-6"
PJI 80ws	18	32'-5"	30'-5"	28'-1"	31'-1"	29'-2"	27'-0"	29'-7"	27'-9"	25'-8"
	20	35'-1"	32'-11"	30'-5"	33'-9"	31'-8"	29'-3"	32'-0"	30'-1"	27'-10"
	24	40'-3"	37'-9"	34'-6"	38'-8"	36'-4"	33'-7"	36'-9"	34'-6"	31'-11"
PJI 90	11-7/8	24'-3"	22'-9"	21'-0"	23'-3"	21'-10"	20'-2"	22'-2"	20'-9"	19'-2"
	14	27'-7"	25'-10"	23'-10"	26'-6"	24'-10"	22'-11"	25'-2"	23'-7"	21'-10"
	16	30'-6"	28'-7"	26'-5"	29'-4"	27'-6"	25'-5"	27'-10"	26'-2"	24'-2"
PJI 90ws	18	33'-5"	31'-4"	28'-11"	32'-1"	30'-1"	27'-10"	30'-6"	28'-7"	26'-5"
	20	36'-2"	33'-11"	31'-4"	34'-9"	32'-7"	30'-1"	33'-0"	31'-0"	28'-8"
	24	41'-6"	38'-11"	35'-11"	39'-10"	37'-4"	34'-7"	37'-10"	35'-6"	32'-10"



Allowable Roof Spans—Simple Span (continued)

TABLE 14
Simple Span Live Load = 50 psf Dead Load = 15 psf

Series	Depth	Slope of 1/4:12 to 4:12			Slope of 4:12 to 8:12			Slope of 8:12 to 12:12		
		16" oc	19.2" oc	24" oc	16" oc	19.2" oc	24" oc	16" oc	19.2" oc	24" oc
PJI 40	9-1/2	15'-4"	14'-4"	13'-3"	14'-8"	13'-9"	12'-9"	14'-0"	13'-1"	12'-1"
	11-7/8	18'-5"	17'-3"	15'-6"	17'-8"	16'-7"	15'-3"	16'-9"	15'-9"	14'-7"
	14	20'-11"	19'-1"	17'-1"	20'-1"	18'-10"	16'-10"	19'-1"	17'-11"	16'-6"
PJI 60	9-1/2	16'-3"	15'-3"	14'-1"	15'-7"	14'-8"	13'-6"	14'-10"	13'-11"	12'-10"
	11-7/8	19'-6"	18'-4"	16'-11"	18'-9"	17'-7"	16'-3"	17'-10"	16'-9"	15'-5"
	14	22'-3"	20'-11"	19'-3"	21'-5"	20'-1"	18'-6"	20'-4"	19'-1"	17'-8"
PJI 65	11-7/8	20'-5"	19'-2"	17'-8"	19'-7"	18'-5"	17'-0"	18'-8"	17'-6"	16'-2"
	14	23'-3"	21'-9"	20'-1"	22'-4"	20'-11"	19'-4"	21'-3"	19'-11"	18'-5"
	16	25'-9"	24'-2"	21'-2"	24'-9"	23'-3"	21'-5"	23'-6"	22'-1"	20'-5"
PJI 80	9-1/2	18'-1"	16'-11"	15'-8"	17'-5"	16'-4"	15'-1"	16'-7"	15'-6"	14'-4"
	11-7/8	21'-8"	20'-4"	18'-9"	20'-10"	19'-7"	18'-1"	19'-10"	18'-7"	17'-2"
	14	24'-9"	23'-2"	21'-5"	23'-9"	22'-3"	20'-7"	22'-7"	21'-2"	19'-7"
PJI 80ws	18	30'-0"	28'-1"	25'-11"	28'-9"	27'-0"	24'-11"	27'-4"	25'-8"	23'-9"
	20	32'-6"	30'-5"	28'-1"	31'-2"	29'-3"	27'-0"	29'-8"	27'-10"	25'-9"
	24	37'-3"	34'-11"	31'-8"	35'-9"	33'-7"	31'-0"	34'-0"	31'-11"	29'-6"
PJI 90	11-7/8	22'-5"	21'-0"	19'-4"	21'-6"	20'-2"	18'-7"	20'-6"	19'-2"	17'-9"
	14	25'-5"	23'-10"	22'-0"	24'-6"	22'-11"	21'-2"	23'-3"	21'-10"	20'-2"
	16	28'-3"	26'-5"	23'-4"	27'-1"	25'-5"	23'-6"	25'-9"	24'-2"	22'-4"
PJI 90ws	18	30'-10"	28'-11"	26'-8"	29'-8"	27'-10"	25'-8"	28'-2"	26'-5"	24'-6"
	20	33'-5"	31'-4"	28'-11"	32'-1"	30'-1"	27'-10"	30'-6"	28'-8"	26'-6"
	24	38'-4"	35'-11"	33'-2"	36'-10"	34'-7"	31'-11"	35'-0"	32'-10"	30'-5"



NOTES for Tables 11, 12, 13 and 14

1. The maximum tabulated span is the horizontal clear distance between bearing supports, and applicable to single span, or single span + 2ft. overhang roof construction. The live load deflection is limited to $L/360$, and total load deflection is limited to $L/180$.
2. Design is as per NBCC and CSA O86 with a load duration factor (LDF) of 1.0.
3. Minimum bearing lengths must be 1-3/4" for end bearings and 3-1/2" for interior bearings.
4. Web stiffeners are required for all PJI Joists in the span tables if the Joist is over 16" deep.
5. Web stiffeners are required for I-Joists seated in hangers where the top flange is not laterally supported.
6. Lateral support must be provided at all bearing locations to prevent lateral displacement and rotation.
7. I-Joists shall be used in a dry, well ventilated environment where the average moisture content will not exceed 15% over a year period and does not exceed 19% at any time.
8. Point loads from above over bearing supports shall be properly transferred by squash blocks or pass-thru framing.
9. Continuous lateral support must be provided for the top and bottom flanges on the compression edge. Continuous lateral support is considered to be a maximum unbraced length of 24". This is normally provided by sheathing and/or framing members, which must be adequately anchored to the member and supporting structure.

Allowable Roof Uniform Load Capacities

TABLE 15
P3 Joist — PJI 40

Allowable uniform loads (PLF) Roof

Clear Span (ft)	9'-1/2"				11'-7/8"				14"				16"			
	Unfactored Loads Based on Deflection			Factored Total Load	Unfactored Loads Based on Deflection			Factored Total Load	Unfactored Loads Based on Deflection			Factored Total Load	Unfactored Loads Based on Deflection			Factored Total Load
	Live		Total L/180		Live		Total L/180		Live		Total L/180		Live		Total L/180	
	L/360	L/240		L/360	L/240	L/360		L/240	L/360	L/240						
8	384	-	-	419	-	-	-	419	-	-	-	419	-	-	-	419
9	287	-	-	374	-	-	-	374	-	-	-	374	-	-	-	374
10	219	328	-	338	-	-	-	338	-	-	-	338	-	-	-	338
11	170	256	-	285	277	-	-	308	-	-	-	308	-	-	-	308
12	135	202	-	240	221	-	-	283	-	-	-	283	-	-	-	283
13	108	163	-	205	179	-	-	261	253	-	-	261	-	-	-	261
14	88	133	177	178	146	220	-	230	208	-	-	243	-	-	-	243
15	73	110	146	155	121	182	-	201	173	-	-	227	-	-	-	227
16	61	91	122	137	102	153	-	177	145	-	-	213	194	-	-	213
17	51	77	103	121	86	129	-	157	123	185	-	190	165	-	-	201
18	43	65	87	108	73	110	-	140	105	158	-	169	141	-	-	190
19	37	56	75	97	63	94	126	126	90	136	-	152	121	-	-	176
20	32	48	65	88	54	82	109	114	78	118	-	137	105	158	-	159
21	28	42	56	80	47	71	95	104	68	102	-	125	92	138	-	145
22	24	37	49	73	41	62	83	94	60	90	-	114	81	121	-	132
23	21	32	43	67	36	55	73	86	53	79	-	104	71	107	-	121
24	19	28	38	61	32	48	65	79	47	70	94	96	63	95	-	111
25	17	25	34	56	28	43	57	73	41	62	83	88	56	84	-	102
26	15	22	30	52	25	38	51	68	37	56	74	82	50	75	-	95
27	13	20	27	48	23	34	46	63	33	50	67	76	45	67	-	88
28	-	-	-	-	20	31	41	58	30	45	60	70	40	61	81	82
29	-	-	-	-	18	28	37	54	27	40	54	66	36	55	73	76
30	-	-	-	-	17	25	34	51	24	37	49	61	33	50	66	71
31	-	-	-	-	15	23	31	48	22	33	44	58	30	45	60	67
32	-	-	-	-	14	21	28	45	20	30	41	54	27	41	55	63
33	-	-	-	-	12	19	25	42	18	28	37	51	25	38	50	59
34	-	-	-	-	11	17	23	40	17	25	34	48	23	34	46	56

NOTES for Tables 15, 16, 17, 18, 18A, 19 and 19A

1. Clear sloped span is the distance between the face of the supports (measured on the sloped length).
2. The load values are for standard term load duration and dry service conditions only. The dead load must not exceed the live/snow load.
3. The load values above represent the worst case of simple or multiple spans member applications.
4. Design of continuous spans is based on the longest span. The shortest span must not be less than 50% of the longest span.
5. Provide continuous lateral support for top & bottom flanges. Provide lateral support at points of bearing to prevent twisting of joist.
6. The unfactored load columns are based on deflection only. The factored load column is based on strength only. Unfactored live/snow load (either L/360 or L/240), unfactored total load, and total factored load must be checked. Where the unfactored load column is blank, the total factored load column governs.
7. Provide min. 1-3/4" bearing at end supports and 3-1/2" bearing at interior support minimum.
8. **Web stiffeners are required at each support for depths > 16".**
9. The loads have been calculated in accordance with CSA O86 and NBCC

Allowable Roof Uniform Load Capacities (continued)

TABLE 16

P3 Joist — PJI 60

Allowable uniform loads (PLF) Roof

Clear Span (ft)	9-1/2"				11-7/8"				14"				16"			
	Unfactored Loads Based on Deflection			Factored Total Load	Unfactored Loads Based on Deflection			Factored Total Load	Unfactored Loads Based on Deflection			Factored Total Load	Unfactored Loads Based on Deflection			Factored Total Load
	Live		Total L/180		Live		Total L/180		Live		Total L/180		Live		Total L/180	
	L/360	L/240		L/360	L/240	L/360		L/240	L/360	L/240						
8	-	-	-	419	-	-	-	419	-	-	-	419	-	-	-	419
9	331	-	-	374	-	-	-	374	-	-	-	374	-	-	-	374
10	254	-	-	338	-	-	-	338	-	-	-	338	-	-	-	338
11	198	298	-	308	-	-	-	308	-	-	-	308	-	-	-	308
12	158	237	-	283	257	-	-	283	-	-	-	283	-	-	-	283
13	127	191	255	261	209	-	-	261	-	-	-	261	-	-	-	261
14	104	156	208	243	172	-	-	243	-	-	-	243	-	-	-	243
15	86	129	172	215	143	214	-	227	204	-	-	227	-	-	-	227
16	72	108	144	189	120	180	-	213	172	-	-	213	-	-	-	213
17	61	91	122	168	101	152	-	201	146	-	-	201	195	-	-	201
18	52	78	104	150	86	130	173	190	125	188	-	190	167	-	-	190
19	44	67	89	135	74	112	149	175	108	162	-	180	144	-	-	180
20	38	57	77	122	64	97	129	158	93	140	-	171	126	-	-	171
21	33	50	67	110	56	84	113	143	81	122	-	163	110	-	-	163
22	29	44	58	101	49	74	99	131	71	107	143	156	96	145	-	156
23	25	38	51	92	43	65	87	120	63	95	126	144	85	128	-	149
24	22	34	45	85	38	58	77	110	56	84	112	132	75	113	-	143
25	20	30	40	78	34	51	68	101	50	75	100	122	67	101	135	137
26	18	27	36	72	30	46	61	94	44	67	89	113	60	90	121	131
27	16	24	32	67	27	41	55	87	40	60	80	105	54	81	108	122
28	-	-	-	-	24	37	49	81	36	54	72	98	49	73	98	113
29	-	-	-	-	22	33	44	75	32	49	65	91	44	66	88	106
30	-	-	-	-	20	30	40	71	29	44	59	85	40	60	80	99
31	-	-	-	-	18	27	37	66	27	40	54	80	36	55	73	92
32	-	-	-	-	16	25	33	62	24	37	49	75	33	50	67	87
33	-	-	-	-	15	23	30	58	22	33	45	70	30	45	61	82
34	-	-	-	-	14	21	28	55	20	31	41	66	28	42	56	77

See notes under Table 15

Allowable Roof Uniform Load Capacities (continued)

TABLE 17

P3 Joist — PJI 65

Allowable uniform loads (PLF) Roof

Clear Span (ft)	11-7/8"				14"				16"			
	Unfactored Loads Based on Deflection			Factored Total Load	Unfactored Loads Based on Deflection			Factored Total Load	Unfactored Loads Based on Deflection			Factored Total Load
	Live		Total L/180		Live		Total L/180		Live		Total L/180	
	L/360	L/240		L/360	L/240	L/360		L/240				
8	-	-	-	427	-	-	-	459	-	-	-	460
9	-	-	-	381	-	-	-	410	-	-	-	410
10	-	-	-	344	-	-	-	370	-	-	-	370
11	-	-	-	314	-	-	-	337	-	-	-	337
12	287	-	-	288	-	-	-	310	-	-	-	310
13	234	-	-	266	-	-	-	286	-	-	-	286
14	193	-	-	248	-	-	-	266	-	-	-	266
15	161	-	-	232	227	-	-	248	-	-	-	248
16	135	203	-	217	192	-	-	233	-	-	-	233
17	115	172	-	205	163	-	-	220	216	-	-	220
18	98	147	-	193	140	-	-	207	186	-	-	207
19	84	127	169	177	121	181	-	197	160	-	-	197
20	73	110	147	160	105	157	-	187	140	-	-	187
21	64	96	128	145	92	138	-	175	122	-	-	178
22	56	84	112	133	80	121	-	160	107	161	-	170
23	49	74	99	121	71	107	142	146	95	143	-	163
24	44	66	88	112	63	95	126	134	84	127	-	156
25	39	58	78	103	56	84	113	124	75	113	-	144
26	35	52	70	95	50	75	101	115	67	101	-	133
27	31	47	62	88	45	68	90	106	60	91	121	124
28	28	42	56	82	40	61	81	99	54	82	109	115
29	25	38	51	77	37	55	74	92	49	74	99	107
30	23	34	46	72	33	50	67	86	45	67	90	100
31	21	31	42	67	30	45	61	81	41	61	82	94
32	19	28	38	63	27	41	55	76	37	56	75	88
33	17	26	35	59	25	38	51	71	34	51	68	83
34	16	24	32	56	23	35	46	67	31	47	63	78

See notes under table 15

Allowable Roof Uniform Load Capacities (continued)

TABLE 18

P3 Joist — PJI 80

Allowable uniform loads (PLF) Roof

Clear Span (ft)	9-1/2"				11-7/8"				14"				16"			
	Unfactored Loads Based on Deflection			Factored Total Load	Unfactored Loads Based on Deflection			Factored Total Load	Unfactored Loads Based on Deflection			Factored Total Load	Unfactored Loads Based on Deflection			Factored Total Load
	Live		Total L/180		Live		Total L/180		Live		Total L/180		Live		Total L/180	
	L/360	L/240		L/360	L/240		L/360	L/240		L/360	L/240		L/360	L/240		
8	-	-	-	420	-	-	-	427	-	-	-	459	-	-	-	497
9	-	-	-	375	-	-	-	381	-	-	-	410	-	-	-	443
10	328	-	-	338	-	-	-	344	-	-	-	370	-	-	-	400
11	259	-	-	308	-	-	-	314	-	-	-	337	-	-	-	365
12	208	-	-	283	-	-	-	288	-	-	-	310	-	-	-	335
13	169	253	-	262	-	-	-	266	-	-	-	286	-	-	-	310
14	139	208	-	243	225	-	-	248	-	-	-	266	-	-	-	288
15	115	173	-	227	188	-	-	232	-	-	-	249	-	-	-	269
16	97	145	194	213	159	-	-	217	224	-	-	234	-	-	-	253
17	82	123	164	201	135	203	-	205	192	-	-	220	-	-	-	238
18	70	105	140	190	116	174	-	193	165	-	-	208	218	-	-	225
19	60	90	121	180	100	150	-	183	142	-	-	197	189	-	-	213
20	52	78	105	171	87	130	174	174	124	186	-	187	165	-	-	203
21	45	68	91	157	76	114	152	166	108	163	-	179	145	-	-	193
22	40	60	80	143	66	100	133	159	95	143	-	171	128	-	-	184
23	35	53	70	131	59	88	118	152	84	127	-	163	113	170	-	177
24	31	47	62	121	52	78	104	146	75	113	150	156	100	151	-	169
25	27	41	55	111	46	69	93	140	67	100	134	150	90	135	-	163
26	24	37	49	103	41	62	83	134	60	90	120	145	80	121	-	156
27	22	33	44	96	37	56	74	124	54	81	108	139	72	109	145	151
28	-	-	-	-	33	50	67	115	48	73	97	134	65	98	131	145
29	-	-	-	-	30	45	61	108	44	66	88	130	59	89	119	140
30	-	-	-	-	27	41	55	101	40	60	80	121	54	81	108	136
31	-	-	-	-	25	37	50	94	36	54	73	114	49	73	98	131
32	-	-	-	-	23	34	46	88	33	50	66	107	45	67	90	124
33	-	-	-	-	21	31	42	83	30	45	61	100	41	61	82	116
34	-	-	-	-	19	28	38	78	28	42	56	94	37	56	75	110

See notes under Table 15

Slope Factor

roof slope / 12	2	3	4	5	6	7	8	9	10	11	12
unfactored live load	0.986	0.970	0.949	0.923	0.894	0.864	0.832	0.800	0.768	0.737	0.707
unfactored total load	0.973	0.941	0.900	0.852	0.800	0.746	0.692	0.640	0.590	0.543	0.500
factored loads	0.986	0.970	0.949	0.923	0.894	0.864	0.832	0.800	0.768	0.737	0.707

Allowable Roof Uniform Load Capacities (continued)

TABLE 18A

P3 Joist — PJI 80 with Web Stiffeners

Allowable uniform loads (PLF) Roof

Clear Span (ft)	18"				20"				24"			
	Unfactored Loads Based on Deflection			Factored Total Load	Unfactored Loads Based on Deflection			Factored Total Load	Unfactored Loads Based on Deflection			Factored Total Load
	Live		Total L/180		Live		Total L/180		Live		Total L/180	
	L/360	L/240		L/360	L/240	L/360		L/240				
12	-	-	-	405	-	-	-	405	-	-	-	405
13	-	-	-	375	-	-	-	375	-	-	-	375
14	-	-	-	349	-	-	-	349	-	-	-	349
15	-	-	-	326	-	-	-	326	-	-	-	326
16	-	-	-	306	-	-	-	306	-	-	-	306
17	-	-	-	288	-	-	-	288	-	-	-	288
18	-	-	-	272	-	-	-	272	-	-	-	272
19	239	-	-	258	-	-	-	258	-	-	-	258
20	209	-	-	245	-	-	-	245	-	-	-	245
21	184	-	-	234	228	-	-	234	-	-	-	234
22	162	-	-	223	202	-	-	223	-	-	-	223
23	144	-	-	214	179	-	-	214	-	-	-	214
24	128	192	-	205	160	-	-	205	-	-	-	205
25	114	172	-	197	143	-	-	197	-	-	-	197
26	103	154	-	189	128	-	-	189	187	-	-	189
27	92	139	-	182	116	174	-	182	169	-	-	182
28	83	125	167	176	105	157	-	176	153	-	-	176
29	76	114	152	170	95	142	-	170	139	-	-	170
30	69	103	138	159	86	130	-	164	127	-	-	164
31	63	94	126	149	79	118	158	159	116	-	-	159
32	57	86	115	140	72	108	144	154	106	-	-	154
33	52	79	105	132	66	99	132	146	97	146	-	149
34	48	72	97	124	61	91	122	137	89	134	-	145
35	44	67	89	117	56	84	112	130	82	124	-	141
36	41	61	82	111	51	77	103	123	76	114	-	137
37	38	57	76	105	47	71	95	116	70	106	-	133
38	35	53	70	99	44	66	88	110	65	98	-	130
39	32	49	65	94	41	61	82	104	61	91	122	124
40	30	45	60	90	38	57	76	99	56	85	113	118
41	28	42	56	85	35	53	71	95	52	79	105	113
42	26	39	52	81	33	50	66	90	49	74	98	107
43	24	37	49	78	31	46	62	86	46	69	92	102
44	23	34	46	74	29	43	58	82	43	64	86	98

See notes under Table 15

Slope Factor

roof slope / 12	2	3	4	5	6	7	8	9	10	11	12
unfactored live load	0.986	0.970	0.949	0.923	0.894	0.864	0.832	0.800	0.768	0.737	0.707
unfactored total load	0.973	0.941	0.900	0.852	0.800	0.746	0.692	0.640	0.590	0.543	0.500
factored loads	0.986	0.970	0.949	0.923	0.894	0.864	0.832	0.800	0.768	0.737	0.707

Allowable Roof Uniform Load Capacities (continued)

TABLE 19
P3 Joist — PJI 90

Allowable uniform loads (PLF) Roof

Clear Span (ft)	11-7/8"				14"				16"			
	Unfactored Loads Based on Deflection			Factored Total Load	Unfactored Loads Based on Deflection			Factored Total Load	Unfactored Loads Based on Deflection			Factored Total Load
	Live		Total L/180		Live		Total L/180		Live		Total L/180	
	L/360	L/240		L/360	L/240	L/360		L/240				
8	-	-	-	427	-	-	-	459	-	-	-	497
9	-	-	-	381	-	-	-	410	-	-	-	443
10	-	-	-	344	-	-	-	370	-	-	-	400
11	-	-	-	314	-	-	-	337	-	-	-	365
12	-	-	-	288	-	-	-	310	-	-	-	335
13	-	-	-	266	-	-	-	286	-	-	-	310
14	243	-	-	248	-	-	-	266	-	-	-	288
15	203	-	-	232	-	-	-	249	-	-	-	269
16	172	-	-	217	-	-	-	234	-	-	-	253
17	146	-	-	205	206	-	-	220	-	-	-	238
18	125	188	-	193	178	-	-	208	-	-	-	225
19	108	163	-	183	154	-	-	197	203	-	-	213
20	94	141	-	174	134	-	-	187	177	-	-	203
21	82	124	165	166	117	176	-	179	156	-	-	193
22	72	109	145	159	103	155	-	171	137	-	-	184
23	64	96	128	152	91	137	-	163	122	-	-	177
24	57	85	114	146	81	122	-	156	108	163	-	169
25	50	76	101	140	72	109	145	150	97	145	-	163
26	45	68	91	134	65	98	130	145	87	130	-	156
27	40	61	81	130	58	88	117	139	78	117	-	151
28	36	55	73	125	53	79	106	134	70	106	141	145
29	33	50	66	121	48	72	96	130	64	96	128	140
30	30	45	60	117	43	65	87	125	58	87	116	136
31	27	41	55	113	39	59	79	121	53	79	106	131
32	25	37	50	108	36	54	72	118	48	73	97	127
33	23	34	46	102	33	49	66	114	44	66	89	123
34	21	31	42	96	30	45	61	111	40	61	81	120

See notes under Table 19A

Allowable Roof Uniform Load Capacities (continued)

TABLE 19A

P3 Joist — PJI 90 with Web Stiffeners

Allowable uniform loads (PLF) Roof

Clear Span (ft)	18"				20"				24"			
	Unfactored Loads Based on Deflection			Factored Total Load	Unfactored Loads Based on Deflection			Factored Total Load	Unfactored Loads Based on Deflection			Factored Total Load
	Live		Total L/180		Live		Total L/180		Live		Total L/180	
	L/360	L/240		L/360	L/240	L/360		L/240				
12	-	-	-	405	-	-	-	405	-	-	-	405
13	-	-	-	375	-	-	-	375	-	-	-	375
14	-	-	-	349	-	-	-	349	-	-	-	349
15	-	-	-	326	-	-	-	326	-	-	-	326
16	-	-	-	306	-	-	-	306	-	-	-	306
17	-	-	-	288	-	-	-	288	-	-	-	288
18	-	-	-	272	-	-	-	272	-	-	-	272
19	257	-	-	258	-	-	-	258	-	-	-	258
20	225	-	-	245	-	-	-	245	-	-	-	245
21	198	-	-	234	-	-	-	234	-	-	-	234
22	175	-	-	223	217	-	-	223	-	-	-	223
23	155	-	-	214	193	-	-	214	-	-	-	214
24	139	-	-	205	172	-	-	205	-	-	-	205
25	124	186	-	197	154	-	-	197	-	-	-	197
26	111	167	-	189	139	-	-	189	-	-	-	189
27	100	151	-	182	125	-	-	182	-	-	-	182
28	91	136	-	176	113	170	-	176	165	-	-	176
29	82	123	165	170	103	154	-	170	150	-	-	170
30	75	112	150	164	94	141	-	164	137	-	-	164
31	68	102	137	159	85	128	-	159	125	-	-	159
32	62	94	125	154	78	117	-	154	115	-	-	154
33	57	86	115	149	72	108	144	149	105	-	-	149
34	52	79	105	145	66	99	132	145	97	-	-	145
35	48	72	97	141	61	91	122	141	89	134	-	141
36	44	67	89	135	56	84	112	137	83	124	-	137
37	41	62	83	128	52	78	104	133	76	115	-	133
38	38	57	76	122	48	72	96	130	71	106	-	130
39	35	53	71	115	44	67	89	126	66	99	-	126
40	33	49	66	110	41	62	83	122	61	92	123	123
41	30	46	61	104	38	58	77	116	57	86	115	120
42	28	43	57	100	36	54	72	110	53	80	107	117
43	26	40	53	95	33	50	67	105	50	75	100	115
44	25	37	50	91	31	47	63	100	47	70	94	112

NOTES for Tables 15, 16, 17, 18, 18A, 19 and 19A

1. Clear sloped span is the distance between the face of the supports (measured on the sloped length).
2. The load values are for standard term load duration and dry service conditions only. The dead load must not exceed the live/snow load.
3. The load values above represent the worst case of simple or multiple spans member applications.
4. Design of continuous spans is based on the longest span. The shortest span must not be less than 50% of the longest span.
5. Provide continuous lateral support for top & bottom flanges. Provide lateral support at points of bearing to prevent twisting of joist.
6. The unfactored load columns are based on deflection only. The factored load column is based on strength only. Unfactored live/snow load (either L/360 or L/240), unfactored total load, and total factored load must be checked. Where the unfactored load column is blank, the total factored load column governs.
7. Provide min. 1-3/4" bearing at end supports and 3-1/2" bearing at interior support minimum.
8. **Web stiffeners are required at each support for depths > 16".**
9. The loads have been calculated in accordance with CSA O86 and NBCC

P3 Joist Design Properties

TABLE 20
Factored Resistance for P3 Joists¹

Series	Depth (in)	EI ² (10 ⁶ lbf-in. ²)	Mr ³ (lbf-ft)	Vr ⁴ (lbf)	K ⁵ (10 ⁶ lbf)	Self Weight (plf)	Factored Vertical Bearing (lbf/ft)
PJI 40	9-1/2	193	4,549	2,210	4.94	2.6	2,900
	11-7/8	330	5,896	2,557	6.18	2.9	2,900
	14	482	7,102	2,865	7.28	3.1	2,900
	16	657	8,233	3,157	8.32	3.4	2,900
PJI 60	9-1/2	231	6,287	2,210	4.94	2.6	2,900
	11-7/8	396	8,150	2,557	6.18	2.9	2,900
	14	584	9,805	2,865	7.28	3.1	2,900
	16	799	11,368	3,157	8.32	3.4	2,900
PJI 65	11-7/8	454	8,265	2,557	6.18	3.3	2,900
	14	664	9,956	2,865	7.28	3.6	2,900
	16	901	11,548	3,157	8.32	3.8	2,900
PJI 80	9-1/2	321	8,940	2,218	4.94	3.4	2,900
	11-7/8	547	11,593	2,604	6.18	3.6	2,900
	14	802	13,954	2,944	7.28	3.8	2,900
	16	1,092	16,183	3,267	8.32	4.0	2,900
	18	1,413	18,295	3,867	9.36	4.3	2,900
	20	1,790	20,258	4,025	10.4	4.5	2,494
	24	2,687	24,100	4,341	12.48	4.9	2,016
PJI 90	11-7/8	601	14,162	2,604	6.18	3.6	2,900
	14	877	17,056	2,944	7.28	3.8	2,900
	16	1,187	19,784	3,267	8.32	4.0	2,900
	18	1,546	22,362	3,867	9.36	4.3	2,900
	20	1,957	24,757	4,025	10.4	4.5	2,494
	24	2,934	29,455	4,341	12.48	4.9	2,016

NOTES

- The tabulated values are design values for standard duration of load. All values, except EI and K, shall be permitted to be adjusted for other load durations as permitted by the code.
- Bending stiffness (EI) of the P3 Joist
- Factored Moment resistances of the P3 Joist which shall not be increased by any code-allowed repetitive member use factor.
- Factored Shear resistance (V_r) of the P3 Joist
- Coefficient of shear deflection (K) of the P3 Joist (For calculating uniform load and center-point load deflections of the P3 Joist in a simple-span application, use Equations 1 and 2).

1- Uniform Load:

$$\delta = \frac{5\omega_u^4}{384EI} + \frac{\omega_u^2}{K}$$

2- Center-Point Load:

$$\delta = \frac{P_3}{48EI} + \frac{2P_3}{K}$$

Where: δ = calculated deflection (in)

ω = unfactored uniform load (lbf/in)

l = design span (in)

P = concentrated load (lbf)

EI = bending stiffness of the P3 Joist (lbf-in²)

K = coefficient of shear deflection (lbf)

Reaction Capacities for P3 Joist

TABLE 21
Factored Reaction Values for P3 Joist¹

Series	Depth	End Reaction (d) (lbf)				Intermediate Reaction (c) (lbf)			
		1.75" Bearing		4" Bearing		3.5" Bearing		5.5" Bearing	
		Web Stiffeners		Web Stiffeners		Web Stiffeners		Web Stiffeners	
		No	Yes	No	Yes	No	Yes	No	Yes
PJI 40	9-1/2	1,886	2,012	1,989	2,210	4,349	4,577	5,122	5,122
	11-7/8	1,894	2,304	2,257	2,557	4,349	4,806	5,122	5,327
	14	1,894	2,557	2,494	2,865	4,349	5,011	5,122	5,501
	16	1,894	2,762	2,715	3,157	4,349	5,209	5,122	5,674
PJI 60	9-1/2	1,886	2,012	1,989	2,210	4,349	4,577	5,122	5,122
	11-7/8	1,894	2,304	2,257	2,557	4,349	4,806	5,122	5,327
	14	1,894	2,557	2,494	2,865	4,349	5,011	5,122	5,501
	16	1,894	2,762	2,715	3,157	4,349	5,209	5,122	5,674
PJI 65	11-7/8	1,894	2,304	2,257	2,557	4,435	5,209	5,138	5,659
	14	1,894	2,557	2,494	2,865	4,767	5,453	5,422	5,911
	16	1,894	2,762	2,715	3,157	5,154	5,682	5,682	6,156
PJI 80	9-1/2	2,060	2,218	2,218	2,218	4,356	4,933	5,122	5,367
	11-7/8	2,076	2,510	2,510	2,604	4,435	5,209	5,138	5,659
	14	2,091	2,778	2,549	2,944	4,767	5,453	5,422	5,911
	16	2,099	3,023	2,573	3,267	5,154	5,682	5,682	6,156
	18	2,115	3,038	2,604	3,867	5,051	6,235	5,761	6,866
	20	2,131	3,425	2,628	4,025	5,051	6,235	5,761	6,866
PJI 90	11-7/8	2,076	2,510	2,510	2,604	4,435	5,209	5,138	5,659
	14	2,091	2,778	2,549	2,944	4,767	5,453	5,422	5,911
	16	2,099	3,023	2,573	3,267	5,154	5,682	5,682	6,156
	18	2,115	3,038	2,604	3,867	5,051	6,235	5,761	6,866
	20	2,131	3,425	2,628	4,025	5,051	6,235	5,761	6,866
	24	2,155	4,199	2,683	4,341	5,051	6,235	5,761	6,866

NOTES

- The tabulated values are factored resistances for standard term duration of load. All values shall be permitted to be adjusted for other load durations as permitted by the code.
- For end reaction values above 2,450 lbf, bearing stiffeners are required.

P3 Joists Framing Connectors – Single P3 Joists

TABLE 22

Joist Height	Top Flange							Snap In Face Mount							Face Mount Hanger							SIMPSON Strong-Tie
	Model	B Dim	Fastener Type		Factored Resistance			Model	B Dim	Fastener Type		Factored Resistance			Model	B Dim	Fastener Type		Factored Resistance			
			Header	Joist	Uplift (115)	Normal				Header	Joist	Uplift (115)	Normal				Header	Joist	Uplift (115)	Normal		
						DF/SP	SPF						DF/SP	SPF						DF/SP	SPF	
P3 Joist 40, 60 Width = 2-1/2"																						
9-1/2	LT259	2	6-3"	1-#8x1-1/4WS ⁴	105	2560	1725	IUS2.56/9.5	2	8-3"	–	175	2385	1690	LF259	2	10-3"	1-#8x1-1/4WS ⁴	105	2525	2155	
11-7/8	LT25188	2	6-3"	1-#8x1-1/4WS ⁴	105	2560	1725	IUS2.56/11.88	2	10-3"	–	175	2565	1820	LF2511	2	12-3"	1-#8x1-1/4WS ⁴	105	2880	2270	
14	LT2514	2	6-3"	1-#8x1-1/4WS ⁴	105	2560	1725	IUS2.56/14	2	12-3"	–	175	2565	1820	LF2514	2	14-3"	1-#8x1-1/4WS ⁴	105	3235	2385	
16	LT2516	2	6-3"	1-#8x1-1/4WS ⁴	100	2560	1725	IUS2.56/16	2	14-3"	–	175	2725	1935	MIU2.56/16	2-1/2	24-3"	2-10dx1-1/2	375	4930	3485	
P3 Joist 80 Width = 3-1/2"																						
11-7/8	LT351188	2	6-3"	2-#8x1-1/4WS ⁴	105	2560	1725	IUS3.56/11.88	2	12-3"	–	175	2375	1695	LF3511	2	12-3"	2-#8x1-1/4WS ⁴	105	2880	2270	
14	LT3514	2	6-3"	2-#8x1-1/4WS ⁴	105	2560	1725	IUS3.56/14	2	12-3"	–	175	2375	1695	LF3514	2	14-3"	2-#8x1-1/4WS ⁴	105	3235	2385	
16	LT3516	2	6-3"	2-#8x1-1/4WS ⁴	100	2560	1725	IUS3.56/16	2	14-3"	–	175	2375	1695	MIU3.56/16	2-1/2	24-3-1/2"	2-10dx1-1/2	375	4930	3485	
18	MIT418	2-1/2	8-3-1/2"	2-10dx1-1/2	265	3490	2420	No IUS for these depths							MIU3.56/18	2-1/2	26-3-1/2"	2-10dx1-1/2	375	4930	3485	
20	MIT420	2-1/2	8-3-1/2"	2-10dx1-1/2	265	3490	2420								MIU3.56/20	2-1/2	28-3-1/2"	2-10dx1-1/2	375	4930	3485	
22	HIT422	3	10-3-1/2"	2-10dx1-1/2	320	3725	2705								MIU3.56/20	2-1/2	28-3-1/2"	2-10dx1-1/2	375	4930	3485	

TABLE 23

Joist Height	45° Skew							Adjustable Height							Field Slope and Skew						
	Model	B Dim	Fastener Type		Factored Resistance			Model	B Dim	Fastener Type		Factored Resistance			Model	B Dim	Fastener Type		Factored Resistance		
			Header	Joist	Uplift (115)	Normal				Header	Joist	Uplift (115)	Normal				Header	Joist	Uplift (115)	Normal	
						DF/SP	SPF						DF/SP	SPF						DF/SP	SPF
P3 Joist 40, 60 Width = 2-1/2"																					
9-1/2	SUR/L2.56/9	3-3/8	14-3-1/2"	2-10dx1-1/2	385	3950	2805	THAI322	2-1/4	6-3"	2-10dx1-1/2	–	2810	2385	LSSUH310	3-1/2	14-3-1/2"	12-10dx1-1/2	1155	2345	1665
11-7/8	SUR/L2.56/11	3-3/8	16-3-1/2"	2-10dx1-1/2	385	3950	2805	THAI322	2-1/4	6-3"	2-10dx1-1/2	–	2810	2385	LSSUH310	3-1/2	14-3-1/2"	12-10dx1-1/2	1155	2345	1665
14	SUR/L2.56/14	3-3/8	18-3-1/2"	2-10dx1-1/2	385	3950	2805	THAI322	2-1/4	6-3"	2-10dx1-1/2	–	2810	2385	LSSUH310	3-1/2	14-3-1/2"	12-10dx1-1/2	1155	2345	1665
16	SUR/L2.56/14	3-3/8	18-3-1/2"	2-10dx1-1/2	385	3950	2805	See Wood Construction Connectors Catalog for hanger selection							LSSUH310	3-1/2	14-3-1/2"	12-10dx1-1/2	1155	2345	1665
P3 Joist 80 Width = 3-1/2"																					
11-7/8	SUR/L410	2-5/8	14-3-1/2"	6-3-1/2"	1540	4065	2875	THAI422	2-1/4	6-3"	2-10dx1-1/2	–	2810	2385	LSSU410	3-1/2	14-3-1/2"	12-10dx1-1/2	1155	2345	1665
14	SUR/L414	2-5/8	18-3-1/2"	8-3-1/2"	2090	4095	2895	THAI422	2-1/4	6-3"	2-10dx1-1/2	–	2810	2385	LSSU410	3-1/2	14-3-1/2"	12-10dx1-1/2	1155	2345	1665
16	SUR/L414	2-5/8	18-3-1/2"	8-3-1/2"	2090	4095	2895	See Wood Construction Connectors Catalog for hanger selection							See Wood Construction Connectors Catalog for hanger selection						
18	SUR/L414	2-5/8	18-3-1/2"	8-3-1/2"	2090	4095	2895														
20	SUR/L414	2-5/8	18-3-1/2"	8-3-1/2"	2090	4095	2895														
22	SUR/L414	2-5/8	18-3-1/2"	8-3-1/2"	2090	4095	2895														
24	See Wood Construction Connectors Catalog for hanger selection																				

NOTES

- All nails are common wire nails unless noted otherwise.
- Hangers that are marked by green shading in tables require web stiffeners. The I-Joist manufacturer may require web stiffeners for hangers that are not marked by shading.
- THAI hangers require a minimum of 4 top and 2 face nails installed
- WS = Wood Screw

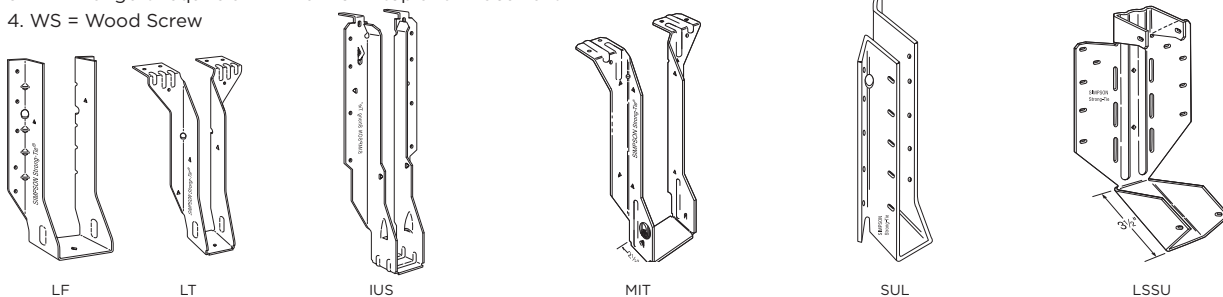

LF – 18 gauge
LT – 18 gauge
 The LF and LT series feature fast and easy installation. No web stiffeners are required.

IUS – 18 gauge
 The IUS is a hybrid hanger that incorporates the advantages of face-mount and top-flange hangers. Joist nails are not required.

MIT – 16 gauge
 The MIT's Positive Angle Nailing helps eliminate splitting of the I-joists' bottom flange. It features uplift capacity and extended seat design.

SUR/L – 16 gauge
SURI/LI – 16 gauge
 All models are skewed 45°. The installation of these hangers does not require a beveled end cut. Web stiffeners are required when used with I-joists.

LSSUH310, LSSU410 – 16 gauge
 LSSU models provide uplift capacity and can be field sloped and/or skewed to 45°. Web stiffeners are required when used with I-joists.

P3 Joists Framing Connectors – Double P3 Joists

TABLE 24

SIMPSON Strong-Tie

Joist Height	Top Flange							Face Mount						45° Skew							
	Model	B Dim	Fastener Type		Factored Resistance			Model	B Dim	Fastener Type		Factored Resistance			Model	B Dim	Fastener Type		Factored Resistance		
			Header	Joist	Uplift (115)	Normal	DF/SP			SPF	Header	Joist	Uplift (115)	Normal			DF/SP	SPF	Header	Joist	Uplift (115)
Double PJI 40, 60 Joist Width = 5"																					
9-1/2	MIT39.5-2	2-1/2	8-3-1/2"	2-10dx1-1/2	265	3490	2420	MIU5.12/9	2-1/2	16-3-1/2"	2-10dx1-1/2	375	4550	3230	HSUR/L5.12/9	2-3/4	12-3-1/2"	2-10dx1-1/2	195	2995	2350
11-7/8	MIT311.88-2	2-1/2	8-3-1/2"	2-10dx1-1/2	265	3490	2420	MIU5.12/11	2-1/2	20-3-1/2"	2-10dx1-1/2	375	4550	3230	HSUR/L5.12/11	2-3/4	16-3-1/2"	2-10dx1-1/2	195	4190	2965
14	MIT314-2	2-1/2	8-3-1/2"	2-10dx1-1/2	265	3490	2420	MIU5.12/14	2-1/2	22-3-1/2"	2-10dx1-1/2	375	4930	3485	HSUR/L5.12/11	2-3/4	16-3-1/2"	2-10dx1-1/2	195	4190	2965
16	MIT5.12/16	2-1/2	8-3-1/2"	2-10dx1-1/2	265	3490	2420	MIU5.12/16	2-1/2	24-3-1/2"	2-10dx1-1/2	375	4930	3485	HSUR/L5.12/11	2-3/4	16-3-1/2"	2-10dx1-1/2	195	4190	2965
Double PJI 80 Joist Width = 7" web stiffeners required																					
11-7/8	B7.12/11.88	2-1/2	14-3-1/2"	8-3-1/2"	1170	5940	3910	HU412-2	2-1/2	22-3-1/2"	8-3-1/2"	2280	5780	4690	HU412-2X ³	2-1/2	22-3-1/2"	8-3-1/2"	1710	3755	3050
14	B7.12/14	2-1/2	14-3-1/2"	8-3-1/2"	1170	5940	3910	HU414-2	2-1/2	26-3-1/2"	12-3-1/2"	3420	7025	5780	HU412-2X ³	2-1/2	26-3-1/2"	12-3-1/2"	2565	4565	3755
16	B7.12/16	2-1/2	14-3-1/2"	8-3-1/2"	1170	5940	3910	HU414-2	2-1/2	26-3-1/2"	12-3-1/2"	3420	7025	5780	HU412-2X ³	2-1/2	26-3-1/2"	12-3-1/2"	2565	4565	3755
18	B7.12/18	2-1/2	14-3-1/2"	8-3-1/2"	1170	5940	3910	HU414-2	2-1/2	26-3-1/2"	12-3-1/2"	3420	7025	5780	HU412-2X ³	2-1/2	26-3-1/2"	12-3-1/2"	2565	4565	3755
20	B7.12/20	2-1/2	14-3-1/2"	8-3-1/2"	1170	5940	3910	HU414-2	2-1/2	26-3-1/2"	12-3-1/2"	3420	7025	5780	HU412-2X ³	2-1/2	26-3-1/2"	12-3-1/2"	2565	4565	3755
22	B7.12/22	2-1/2	14-3-1/2"	8-3-1/2"	1170	5940	3910	HU414-2	2-1/2	26-3-1/2"	12-3-1/2"	3420	7025	5780	See Wood Construction Connectors Catalog for hanger selection						
24	B7.12/24	2-1/2	14-3-1/2"	8-3-1/2"	1170	5940	3910	HU414-2	2-1/2	26-3-1/2"	12-3-1/2"	3420	7025	5780							

TABLE 25

Joist Height	Field Slope							Adjustable Height						
	Model	B Dim	Fastener Type		Factored Resistance			Model	B Dim	Fastener Type		Factored Resistance		
			Header	Joist	Uplift (115)	Normal	DF/SP			SPF	Header	Joist	Uplift (115)	Normal
Double PJI 40, 60 Joist Width = 5"														
9-1/2	LSU5.12 ^a	3-1/2	24-3-1/2"	16-10dx1-1/2	910	2600	1845	THAI-2 ²	2-1/2	6-3"	2-10dx1-1/2	—	2800	2800
11-7/8	LSU5.12 ^a	3-1/2	24-3-1/2"	16-10dx1-1/2	910	2600	1845	THAI-2 ²	2-1/2	6-3"	2-10dx1-1/2	—	2800	2800
14	LSU5.12 ^a	3-1/2	24-3-1/2"	16-10dx1-1/2	910	2600	1845	THAI-2 ²	2-1/2	6-3"	2-10dx1-1/2	—	2800	2800
16	See Wood Construction Connectors Catalog for hanger selection							See Wood Construction Connectors Catalog for hanger selection						
Double PJI 80 Joist Width = 7"														
11-7/8 to 24	See Wood Construction Connectors Catalog for hanger selection							See Wood Construction Connectors Catalog for hanger selection						

NOTES

- Hangers that are marked by green shading in tables require web stiffeners. The I-Joist manufacturer may require web stiffeners for hangers that are not marked by shading.
- THAI hangers require a minimum of 4 top and 2 face nails installed. THAI-2 must be special ordered; specify hanger seat width between 3-1/8" and 5-5/16".
- Skewed option must be special ordered. Specify skew angle and direction (i.e. HU412-2X, SKR45).
- The LSU is field slopable only. Skew options must be special ordered from the factory.

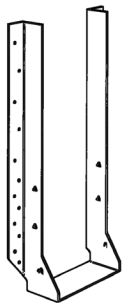

MIU

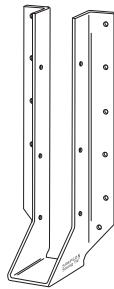

HU

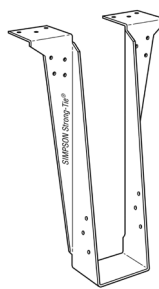

B

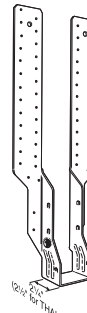

THAI

MIU - 16 gauge

The MIU series features 16 gauge steel and extra nailing for higher loads than the IUT.

HU - 14 gauge

The HU series features uplift capacity and a large selection of sizes and load ranges. HU hangers have triangle holes that can be filled for increased loads. Web stiffeners are required when used with I-joists.

B - 12 gauge

The B Series offer versatility for I-Joist and SCL lumber enhanced load capacity widens the range of application for these hangers.

THAI - 18 gauge

This hanger has extra long straps and can be field-formed to give height adjustability and top-flange hanger convenience. Positive angle nailing helps eliminate splitting of the I-joist's bottom flange. Not all strap nail holes need to be filled for maximum nailing. Web stiffeners are required when used with I-joists.

P3 Products Warranty

Interfor Corporation warrants that the P3 Products manufactured by us or any of our affiliates comply with our specifications, are free from manufacturing defects in materials and workmanship, and will meet or exceed our performance specifications when correctly stored, handled, installed, used and maintained in accordance with our instructions, including the instructions in our P3 Joist User Guides for Canada and the United States, which are available at www.interfor.com/products. Checks, cracks or splits of any P3 Product resulting from the natural physical properties of wood, or any minor edge separation, are not covered by this Warranty unless the condition results in the P3 Product not complying with its specifications.

Please protect your investment! P3 Products must be protected from exposure to moisture. Exposure to moisture beyond incidental exposure during normal construction periods may cause P3 Product failure and will void this limited warranty.

Any Warranty claim must be made in writing to the address below, within thirty (30) days of discovery of the facts substantiating the claim. In support of such Warranty claim, the claimant must provide us with reasonable proof of P3 Product identification in the form of a sample, a photograph of the identifying stamp, or dated receipt. We must be given a reasonable opportunity to inspect the P3 Product. After inspection and verification, if we determine that there is a valid Warranty claim, we will pay to the owner of the structure an amount equal to the reasonable value of the defective P3 Product, or, at our option, we will replace the defective P3 Product. This Warranty does not cover any costs related to installing or removing any P3 Products or replacement products.

INTERFOR CORPORATION AND ITS AFFILIATES DISCLAIM ALL OTHER WARRANTIES AND GUARANTEES, EXPRESS OR IMPLIED, INCLUDING IMPLIED WARRANTIES OF MERCHANTABILITY OR FITNESS FOR A PARTICULAR PURPOSE. NONE OF INTERFOR CORPORATION, ITS AFFILIATES, OR ANY SELLER OF P3 PRODUCTS SHALL BE LIABLE FOR ANY SPECIAL, INCIDENTAL OR CONSEQUENTIAL LOSS OR DAMAGE RELATED TO THE PURCHASE, SALE, OR USE OF ANY P3 PRODUCT.

For additional information on our P3 Products or this Warranty, please contact us at:

Interfor Corporation
Attention: Sales & Marketing - P3 Product Warranty Claims
Address: 1600 - 4720 Kingsway, Metrotower II, Burnaby, BC V5H 4N2, Canada
www.interfor.com/products



Sales Contact:
www.interfor.com
ewpsales@interfor.com

Plant:
Interfor Sault Ste. Marie Division
1195 Peoples Road
Sault Ste. Marie, Ontario
Canada P6C 3W7

Distributed by: